



# User Manual

## ElectroMagnetic Flow Meter

Model: LIM



# Table of Contents

Notices.....3

Warnings.....3

About Electromagnetic Flow Meters .....5

Specifications.....6

Flow Meter Pack .....9

Installation Overview .....10

Installation – Mechanical.....11

Installation – Electrical.....17

Using the Display.....19

Setting up the Flow Meter .....21

Communication Settings .....32

Warranty.....34

Calibration.....34

Trouble Shooting.....35

# Notices

Please read this manual in full and carefully observe the notes and instructions before and during installation, operation and maintenance. The manufacturer cannot be held liable for any damage which occurs as a result of noncompliance with this manual.

**Do not tamper with device.** Should the device be tampered with in any manner other than a procedure which is described and specified in this manual, the warranty is cancelled and the manufacturer is exempt from liability.

**The product is designed exclusively for the described application.** Use of this product in conditions not specified in this manual or, contrary to the manufacturer's instructions, is considered improper handling of the product and will void your warranty. The manufacturer will not be held liable for any damages resulting from improper use of the product.

This manual should be read carefully by relevant personnel and the end user. This manual should be kept with the product and be made available as needed. **Once you install or use the product, you accept that you have read, understood and complied with this manual.**

Compressed Air Alliance endeavours to make the content of this manual correct but is not responsible for omissions or errors and the consequences caused. In case of any doubts or questions regarding this manual or the product, please contact Compressed Air Alliance.

## Warnings

**Ignoring warnings can lead to serious injury and/or cause damage!**

When handling, operating or carrying out maintenance on this product, personnel must employ safe working practices and observe all local health & safety requirements and regulations.

Improper operation or maintenance of this product could be dangerous and result in an accident causing damage to machinery or injury or death.

The manufacturer cannot anticipate every possible circumstance which may represent a potential hazard. Warnings in this manual cover the most common potential hazards and are therefore not all-inclusive. If the user employs an operating procedure, an item of equipment or a method of working which is not specifically recommended by the manufacturer they must ensure that the product will not be damaged or made unsafe and that there is no risk to persons or property.

**NEVER CHANGE ORIGINAL COMPONENTS WITH ALTERNATIVES.**



## Electrical Safety

Any contact with energised parts of the product may lead to an electrical shock which can lead to serious injuries or death. The user shall take all measures necessary to protect against electrical shock.

Consider all local and national regulations for electrical installations.

The system must be disconnected from any power supply during maintenance work.

Any electrical work on the system is only allowed by authorised qualified personal.

## Storage and transportation

- The temperature range for transporting the sensor is between  $-10^{\circ}\text{C}$  to  $60^{\circ}\text{C}$  ( $14^{\circ}\text{F}$  to  $140^{\circ}\text{F}$ ).
- The temperature range for storing the sensor is between  $-10^{\circ}\text{C}$  to  $50^{\circ}\text{C}$  ( $14^{\circ}\text{F}$  to  $122^{\circ}\text{F}$ ) and the humidity is  $<90\%$ , no condensation. Avoid direct UV and solar radiation during storage.

## Cleaning

If you need to clean the sensor it is recommended to use a clean, dry cloth. For stubborn marks, use distilled water or isopropyl alcohol only.

Please note: contamination on the sensor tip will affect calibration and accuracy of the sensor. Removal of the contamination may not fix the issue. Contact Compressed Air Alliance or your local dealer for calibration.

## Disposal

Electronic devices are recyclable material and do not belong in the household waste. The product, accessories and its packing material must be disposed according to local statutory requirements.

# About Electromagnetic Flow Meters

Compressed Air Alliance's electromagnetic flow meter are designed for measuring the flow rate of an electrically conductive liquid in manufacturing and industrial settings.

Electromagnetic flowmeters are based on Faraday's law of electromagnetic induction. Two electromagnetic coils at the upper and lower ends of the flow meter generate a constant or alternating magnetic field.

When the conductive medium flows through the electromagnetic flowmeter, the induced electromotive force can be detected between the left and right electrodes on the wall of the flowmeter tube.

The magnitude of the induced electromotive force is proportional to the electrically conductive medium flow rate, the magnetic induction density of the magnetic field, and the width of the conductor (the inner diameter of the flowmeter measuring tube). The flow rate of the medium is then calculated based on these measurements.

Compressed Air Alliance's electromagnetic flow meter has no moving parts, rotating gears, turbines or bearings. The flow meter provides real time flow rates, total volume, velocity and mass flow in a single unit with both Modbus RTU and 4-20mA outputs. The bi-directional ability allows the flow directions to be detected and recorded separately.

Made from corrosion resistant 304 stainless steel, a titanium probe and PTFE liner, these flow meters are incredibly durable and made for most industrial environments.

## **Benefits of measuring liquid flow**

- Improve product quality and consistency
- Reduce waste and contamination
- Reduce operating costs
- Improve system performance and reliability
- Understand peak and average demands
- Reduce downtime and lost production
- Identify leaks and poor usage

# Specifications

Liquid Flow Meter					
Liquid Mediums	<ul style="list-style-type: none"> <li>• Industrial and Domestic Water</li> <li>• Sewage</li> <li>• Salt and Sea water</li> <li>• Non Corrosive waste water</li> <li>• Acetic and Nitric Acid</li> <li>• Potassium, Sodium, Ammonium and Calcium Hydroxides</li> <li>• Aqua Regia</li> <li>• Other liquids available on request</li> </ul>				
Measurement Range					
Measurement Principal	Faraday's law of electromagnetic induction				
Medium conductivity	>50us/cm				
Medium Temperature Range	<table border="1"> <tr> <td>-20 to +100 °C</td> <td>-4 to 212°F</td> </tr> </table>	-20 to +100 °C	-4 to 212°F		
-20 to +100 °C	-4 to 212°F				
Accuracy					
Measurement Accuracy	<table border="1"> <tr> <td>Flow speed &gt; 1m/s</td> <td>±0.5%</td> </tr> <tr> <td>Flow speed &lt; 1m/s</td> <td>±0.5% ±2mm/s</td> </tr> </table>	Flow speed > 1m/s	±0.5%	Flow speed < 1m/s	±0.5% ±2mm/s
Flow speed > 1m/s	±0.5%				
Flow speed < 1m/s	±0.5% ±2mm/s				
Repetitiveness	0.15%				
Maximum Temperature Measurement Error	±0.1°C				
Outputs					
Output	Analogue: 4 to 20mA (3 wire) Digital: RS485 Modbus / RTU				
Output signals	Flow rate, total volume, velocity and mass flow				
Power					
Power Supply	22-26 vDC, Max 15VA				
Other Information					

Display	In-built Monochrome LCD	
Bi-Directional	Yes	
Pipe Diameters	DN15-DN150 Other sizes available on request	
Flange Connection	DIN	
IP Rating	IP65	
Installation Type	Permanent installation	
Warranty Period	12 months	
Ambient Temperature	-10 to +55°C	-22 to +158°F
Rated Pressure	0-16 bar	0-232 psi
	<b>Materials</b>	
Casing	304 Stainless Steel	
Electrode	Titanium	
Liner	PTFE	

## Flow Range

DN	Pipe Size		Flow Range (m <sup>3</sup> /hr)		Flow Range (gpm)	
	ID (mm)	Inches	Min	Max	Min	Max
15	15	1/2"	0.4	4.0	1.8	17.6
20	20	3/4"	0.8	8.0	3.5	35.2
25	25	1"	1.2	12.0	5.3	52.8
32	32	1.25"	2.0	20.0	8.8	88.0
40	40	1.5"	3.0	30.0	13.2	132
50	50	2"	5.0	50.0	22	220
65	65	2.5"	8.0	80.0	35.2	352
80	80	3"	12.0	120.0	52.8	528
100	100	4"	20.0	200.0	88.0	880
150	150	6"	32.0	320.0	140.8	1408

## Dimensions (mm)

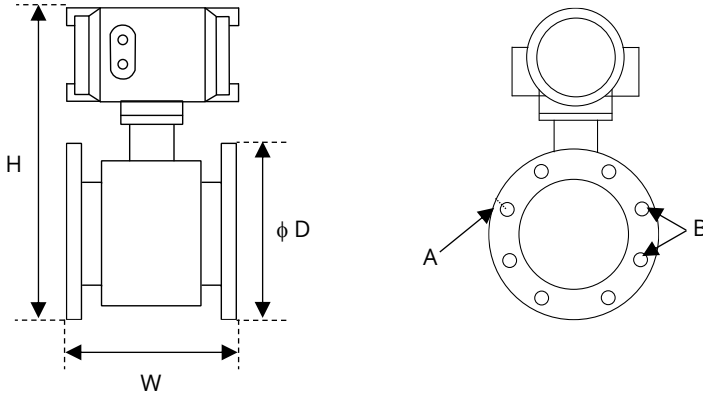

Dimensions (mm)					
DN	W Width from outer edge of flange	H Height	$\phi D$ Diameter of Flange	A Centre of hole to edge of Flange	B No. holes & hole diameter
15	200	326	95	65	4 x 14
20	200	326	105	75	4 x 14
25	200	316	115	85	4 x 14
32	200	331	135	100	4 x 18
40	200	339	145	110	4 x 18
50	200	358	160	125	4 x 18
65	200	370	180	145	4 x 18
80	200	389	195	160	8 x 18
100	250	410	215	180	8 x 18
125	250	440	245	210	8 x 18
150	300	469	280	240	8 x 23



# Flow Meter Pack

Each flow meter pack comes with:

- ✓ 1 x Electromagnetic Flow Meter – Inline style, configured for your liquid type.

**Optional:** 5 meter data cable

## Electromagnetic Flow Meter



## Optional Accessories

The following accessories are available for the flow meter. Talk to your local dealer or Compressed Air Alliance for pricing.



Data Cables



Cloud-based Data Acquisition and Analysis software

# Installation Overview

**Step 1** – Find a suitable section of pipe

- The minimum distance of straight, unobstructed pipe must be:
  - at least 10 pipe diameters (10DN) upstream of the flow meter
  - at least 5 pipe diameters (5DN) downstream of the flow meter
- Make sure the pipe is full of water. Avoid pipe sections where bubbles can form

**Step 2** – Install Flow Meter**Step 3** – Wire the sensor**Step 4** – Check / update the sensor settings**Step 5 (optional)** – Connect the sensor to your SCADA or energy management system**Step 6** – Fill out the Commissioning Report (last page of this manual)

# Installation – Mechanical



**WARNING!** Incorrect installation can damage the sensor or cause it to work incorrectly.



## Notes

- **Before installing the sensor, make sure it is rated for your system** (refer to the “Specifications” section).
  - Use of the product outside specified ranges or operating parameters can lead to malfunctions and may damage the product or system.
- The electromagnetic flowmeter must be installed in a dry and ventilated place.
- The flow meter is designed for indoor use. If using outside, you will need to protect it from sunlight and rain.
- Always use a spanner / wrench to install the product.
- Only use pressure rated materials and parts when installing and maintaining the product Do not allow the flow meter to be flooded.
- Do not use this product in explosive areas.
- Do not install the flow meter in the following locations:
  - Places with large temperature variation. Avoid high temperature radiation from nearby equipment. If the flow meter must be installed in a hot environment, heat insulation and ventilation measures must be taken.
  - Environments with corrosive gases. If the flow meter must be installed in a corrosive environment, and ventilation and anti-corrosion measures must be taken
  - Pipes or environments with strong vibrations. If the flow meter must be installed on a free vibrating pipe, brackets should be fixed to the pipe, on either side of the flow meter.
  - near motors, transformers, or other power sources which are prone to cause electromagnetic interference, near the frequency converter or obtain power from the power distribution cabinet of the frequency converter to avoid interference.
- Do not disassemble the product.
- Please observe local and national regulations before/during installation and operation.

## Step 1 – Find a suitable section of pipe

### Step 1a – Minimum distance of straight pipe

The minimum distance of straight, unobstructed pipe:

- upstream of the flow meter must be at least 10 pipe diameters (10DN)
- downstream of the flow meter must be at least 5 pipe diameters (5DN)



#### Correct Installation

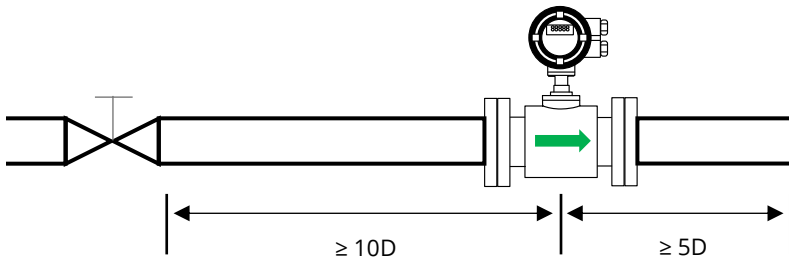
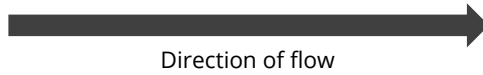
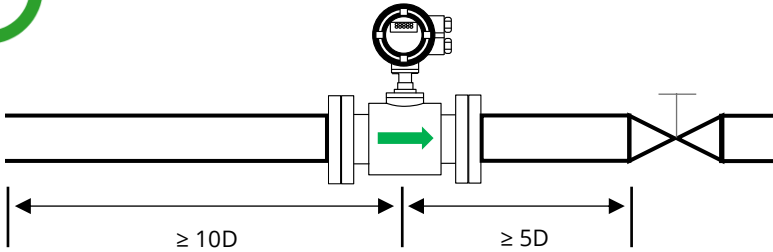

### Step 1b – Flow Direction

The flowmeter can be set to automatically detect the positive and negative flow direction.

The flow direction arrow on the sensor casing indicates the positive flow direction. When installing the meter, make the flow arrow is consistent with the on-site process flow.

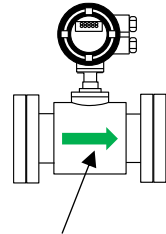

Arrow indicates direction of positive flow



Arrow on flow meter and direction of flow in the pipes are aligned

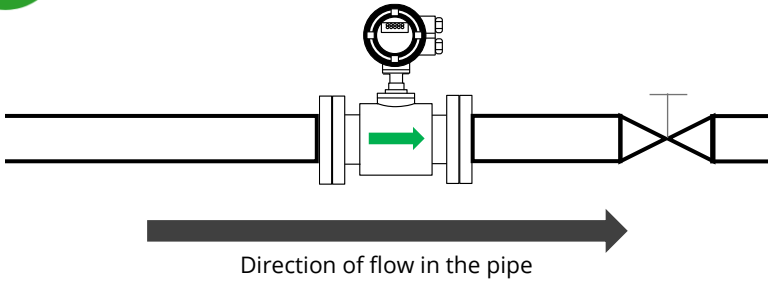

Arrow on flow meter and direction of flow in the pipes in opposite directions

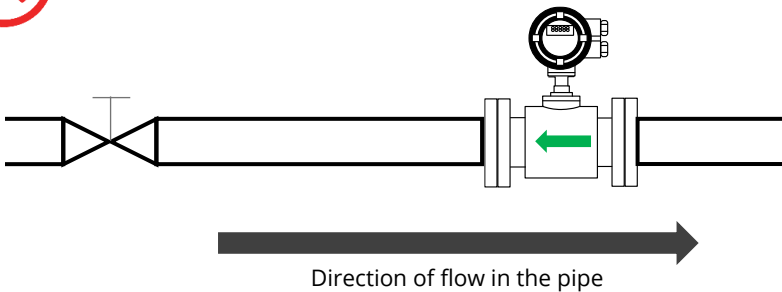

### Step 1c - Avoid Empty Space, Bubbles, and Solid Particles

**Empty Space** - The sensor's electrodes need to be completely submerged in the liquid otherwise incorrect readings can occur.

**Bubbles** - Pipes should be designed to prevent the air bubbles in the fluids from accumulating on the measurement part of the sensor. If a valve exists near the flowmeter, try to mount the flowmeter on the valve's upstream side to prevent a decrease of pressure and air bubbles forming in the pipe.

**Solid Particles** - If the liquid contains solid particles, we recommended that the flow meter is installed vertically on a section of pipe with upward flow direction (so the pipe is full of liquid). This may reduce particles from the liquid and will help to evenly wear the sensor lining.

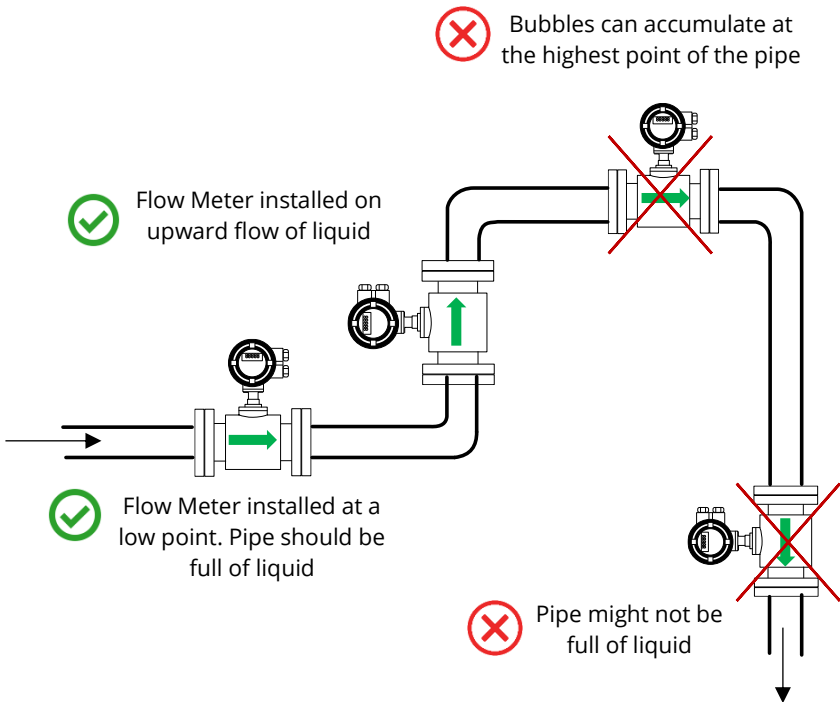

## Step 1d – Other Considerations

Other things to consider when finding a suitable location to install the flow meter:

- **Maintenance**
  - Make sure there is enough space around the flow meter for easy install and maintenance.
  - The electromagnetic flowmeter could be installed on a bypass pipe to ensure the continuous operation of the system when the flowmeter is out of service.
- **Vibrating Pipes** - If installing the flow meter on free-vibrating pipe, you must add pipe supports on either side of the flow meter.
- **Pumps** - The electromagnetic flowmeter must not be installed on the suction side of a pump.
- For pipes with **open discharges**, the electromagnetic flowmeter must be installed at the bottom section (lower part of the pipe).

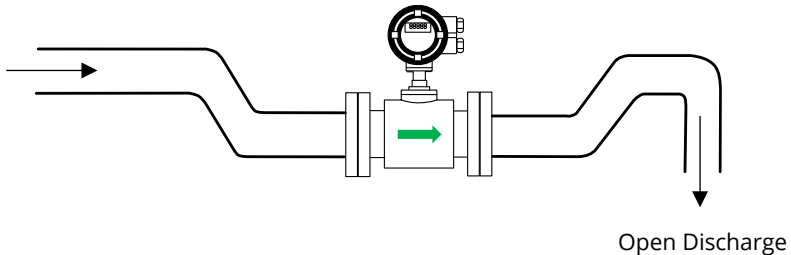

- For locations where fall head of pipes is over 5m, an air valve must be installed on the downstream of the electromagnetic flowmeter
- The flow meter must be installed in a location where **liquid conductivity** is constant. Uneven liquid conductivity can result in incorrect measurements.
- **Injecting chemicals** upstream of the flow meter can cause uneven liquid conductivity and/or damage the lining of the flow meter lining. We suggest you inject chemicals downstream of the flow meter. If chemicals must be injected upstream of the meter, they must be injected at least 30 pipe diameters (30DN) upstream to ensure adequate mixing of liquids.

## Step 2 – Mechanical Installation

- Seal gaskets installed between flanges must have good corrosion resistance and must not protrude into the interior of the pipe.
- Avoid welding or flame cutting near the flow meter to prevent the lining from being deformed due to heat.
- Bolts, nuts and thread information is in the 'Specifications' section of this manual. Use suitable flat washers and spring washer with the bolts.
- **Maintenance** - Regularly tighten the bolts during daily use to prevent looseness of the bolts.

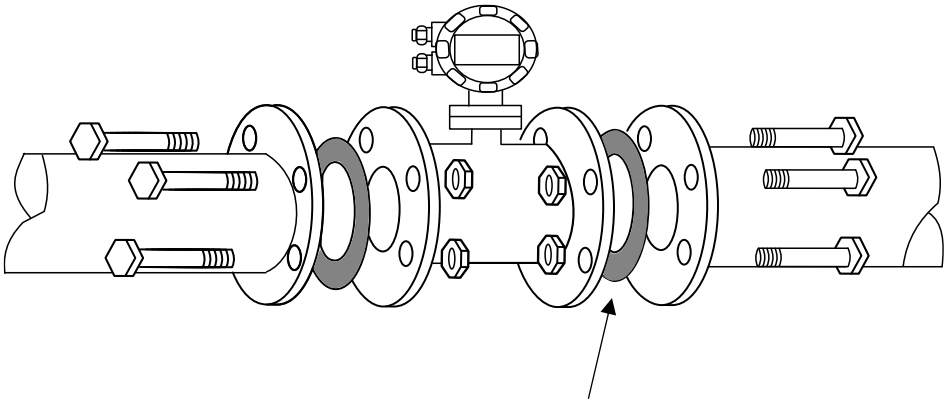

When the flowmeter is installed, the inner diameter of sealing washers shall be slightly larger than that of the pipe to avoid interference to the fluids in the pipe.



# Installation – Electrical



**WARNING!** Incorrect wiring can damage the sensor or cause it to work incorrectly.

## Notes:

- The Electromagnetic Flow Meter uses **24vDC power supply**.
- Consider all local and national safety requirements and regulations for electrical installations.
- **The system must be disconnected from any power supply during installation and maintenance work.**
- Any electrical work on the system is only allowed by authorised and qualified personal.

## Connection descriptions

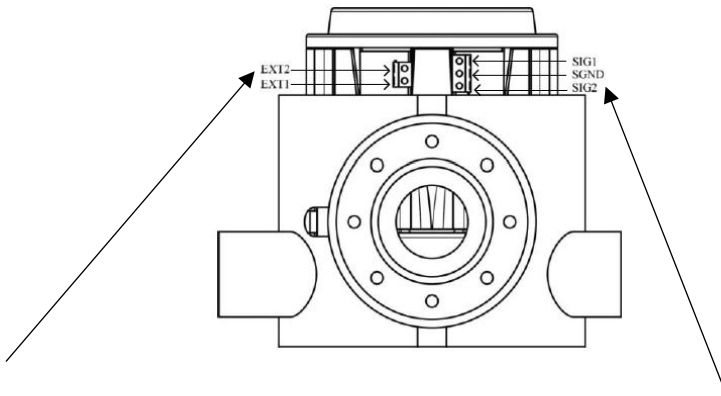

### Excitation output

- EXT1 - Sensor excitation coil positive terminal
- EXT2 - Sensor excitation coil negative terminal

### Signal output

- SIG1-The positive electrode sensor signal
- SIG2--The negative electrode sensor signal
- SGND--Signal ground

## Wiring

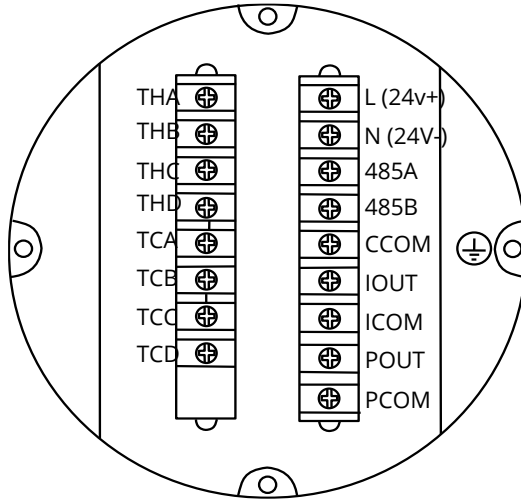

Pin	Description
THA, THB, THC, THD	Water supply temperature (Pt1000)
TCA, TCB, TCC, TCD	Return water temperature (Pt1000)
L	+24vDC (positive pole)
N	-24vDC (negative pole)
485A, 485B, CCOM	Modbus-RTU (RS485) communication 485A = Modbus +   485B = Modbus - CCOM = Modbus ground
IOU, ICOM	4-20mA output connection
POU, PCOM	Pulse/Frequency/Relay out
	Ground - connect ground wire to ground screw
Note: the left terminal is the BTU meter terminal	

**Grounding** - The flow signal produced by the sensor is very weak, usually on the microvolt or millivolt level. Therefore, preventing the influence of external electrical interference is important. Grounding is a very effective measure to address the effects of electrical interference.

# Using the Display

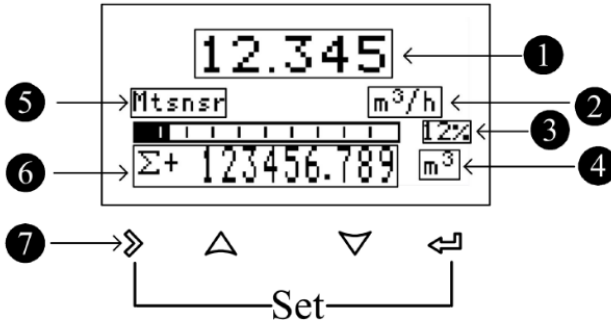

1. Real-time flow
2. Real-time flow unit
3. Real-time flow in percent of flow
4. Accumulation flow unit
5. System alarm information (see next page)
6. Cumulative amount:
  - [Σ+]: Positive flow accumulation | [Σ-]: Negative flow accumulation
  - [Σ]: Net flow accumulation | [V]: Current velocity
  - [MT]: Current conductivity
7. Operation keys: mechanical / photoelectric keys (see table below)

Operation Key	Measuring Mode	Menu Mode	Function Mode	Data Mode
➤	-	Switch Menu categories	-	Data right shift
⏪	Switch accumulative amount	Switch menu subclass	Confirmation	Confirm data
⬆ ⬇	-	-	Selection	Change data
➤ + ⏪	Enter Menu	Exit Menu	-	-

## System Alarm Information

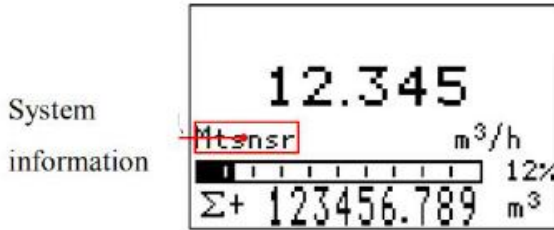

The flow meter’s self-diagnosis function will display an alarm message on general faults.



Display Message	Alarm Meaning
	If the system information section is blank, the system is working well.
Mtsnsr	Sensor is detecting an empty pipe
Hi	The current real-time flow rate exceeds the setting flow limit
Lo	The current real-time flow rate is below the setting flow lower limit
Pls	The pulse output frequency exceeds the setting frequency upper limit
AD_Hi	Sensor signal is greater than the AD sampling of the upper limit
Rng	The current real-time flow rate exceeds the setting flow limit
Rng_Hi	The current real-time flow rate exceeds system AD sampling limit
Pls_Hi	The range scope set by user exceeds the upper limit of pulse output

# Setting up the Flow Meter



After installing the flow meter, you should check / edit the sensor's settings. At a minimum, you should do the Quick Set up. For full configuration details, see the following pages.

## Quick Set up

Press  and  at the same time to enter the Quick Set Up menu

The default **password for quick set up = 300000**

No.	Parameter	Parameter Range	Default value	Comments
1	Sensor drift diameter	3 -2000	50	
2	Flow Range	0 - 99999	35.000	Set the maximum flow limit value
3	Sensor coefficient	0 - 99999	1.0	
4	Zero correlation	0 - 99999	0.0	
5	Accumulation reset	Y, N	N	
6	Flow remove	0 - 99%	1%	
7	Time constant	0 - 99s	2s	
8	Exit configuration	Y, N	N	

## Configuration Details

Various parameters of the flow meter can be configured by the user, as shown in the following tables:

- Table 1 – Flow parameters
- Table 2 – Current Output
- Table 3 – Pulse / Frequency/ Alarm Output
- Table 4 – Alarm parameters
- Table 5 – System settings, eg language, Modbus settings, password

You may need to use password = **200000** to change the parameters below.

### Table 1 – Flow Parameters

These parameters can be changed by the user.

No.	Parameter	Parameter Range	Default value	Comments
1.0	Flow Range	0 - 99999	35.000	Set the maximum flow limit value
1.1	Flow Unit	L, m3, Kg, gal per s, min, h	M3/h	No gal/s. Only gal/min and gal/h
1.2	Fluid Density	0.000 - 99.000	1.000	Used to calculate the mass flow
1.3	Time Constant	0 – 99s	2s	Damping coefficient of the filter
1.4	Flow Resection	0 – 10%	1%	Flow volume is regarded as zero if it is below this setting
1.5	Flow Direction	Positive, Negative	Positive	Used to change the direction of flow, eg if the sensor is installed in the opposite direction to the flow, or if the

No.	Parameter	Parameter Range	Default value	Comments
				signal cables were wired in reverse
	Mode Selection	Positive, Negative, Bidirection	Bidirection	Set the direction of the flow measurement
1.6	Mode Selection sets the direction of the flow measurement. <ul style="list-style-type: none"> <li>• Positive direction only measures forward direction measurement flow.</li> <li>• Negative direction only measures the reverse flow</li> <li>• Bidirection indicates two-way flow measurement</li> </ul>			
	Spike Suppressor Permission	Y, N	N	Used for filtering interference signals
1.7	Indicates whether to enable peak inhibition function. Used for filtering interference signals. When it's set to N, 1-8, 1-9 configuration screens do not display. When the range of signal pulse is greater than parameters set in 1-8 and lasts for a duration less than that set in 1-9, the system will consider it as interference signal and will not measure or display the results.			
1.8	Peak Inhibition Coefficient	0.01 – 0.8 m/s	0.8	
1.9	Peak Inhibition Time	0 – 3 s	1	
The parameters below (1.10 to 1.18) are set by the manufacturer.				
1.10	Flow Correction Permission	Y, N	No	1.10 to 1.18 are set by the Manufacturer.
1.11	Flow Correction Point 1	0.0 – 99.999	0	
1.12	Flow Correction Coefficient 1	0.0 – 99.999	1.000	If you need to change these parameters, contact Compressed Air Alliance.
1.13	Flow Correction Point 2	0.0 – 99.999	0	
1.14	Flow Correction Coefficient 2	0.0 – 99.999	1.000	The Flow Correction Permission function (1.10) uses data in the Flow Correction Points and Flow Correction
1.15	Flow Correction Point 3	0.0 – 99.999	0	

No.	Parameter	Parameter Range	Default value	Comments
1.16	Flow Correction Coefficient 3	0.0 – 99.999	1.000	Coefficients (1.11 to 1.18)
1.17	Flow Correction Point 4	0.0 – 99.999	0	
1.18	Flow Correction Coefficient 4	0.0 – 99.999	1.000	

## Table 2 - Current Output

These parameters can be changed by the user.

No.	Parameter	Parameter Range	Default value	Comments
2.0	Reverse Output Permission	Y, N	N	
2.1	Adjust K	0 – 99999	1.000	Used for adjusting the output current value, $I = Kx + B$
2.2	Adjust B	0 – 99999	0.000	
2.3	Output Current	4.00 – 20.00	-	Display the current value (mA) of the current output

## Table 3 – Pulse / Frequency / Alarm

These parameters can be changed by the user.

No.	Parameter	Parameter Range	Default value	Comments
3.0	Pulse Output Type	Frequency, Pulse, Alarm	Frequency	Optional setting
3.1	Transistor State	High / Low	High	Select the level state of no frequency output, no



No.	Parameter	Parameter Range	Default value	Comments
				pulse equivalent output, no alarm output
3.2	Max Frequency	0 – 5000	2000	Set the corresponding frequency of the real-time flow upper limit
3.3	Pulse Value	0.001 – 999.999	1.0	Set the cumulant that each pulse stands for

## Table 4 – Alarm

These settings are only configurable if you selected 'Alarm' as the Pulse Output Type in menu 3.0 (above)

No.	Parameter	Parameter Range	Default value	Comments
<b>Alarm Contacts</b>				
4.0	Alarm Transistor State	High / Low	High	
4.1	Alarm 1 Output	Y, N	N	Allow contact 1 output of main switch
4.2	Allow Alarm 1 Empty Pipe	Y, N	N	Alarm activates when the system detects an empty pipe
4.3	Allowed Alarm 1 Exceeds Upper Limit	Y, N	N	Alarm activates when the real-time flow is greater than the flow rate upper limit value (set in 4.5)
4.4	Allowed Alarm 1 Exceeds Lower Limit	Y, N	N	Alarm activates when the real-time flow is lower than the flow rate lower limit value (set in 4.6)

No.	Parameter	Parameter Range	Default value	Comments
<b>Alarm Set Up</b>				
4.5	Max. Flow Value Alarm	0 – 99.99%	100%	Set the upper limit alarm value
4.6	Min. Flow Value Alarm	0 – 99.99%	0%	Set the lower limit alarm value
<b>Alarm Hysteresis</b> Used to eliminate the alarm disturbance.				
4.7	<ul style="list-style-type: none"> <li>Upper limit elimination conditions: real-time flow is less than the upper limit alarm value minus return difference</li> <li>Lower limit elimination conditions: real-time flow is greater than the lower limit alarm value plus return difference</li> </ul>			
4.8	Display Alarm Permission	Y, N	N	Allow alarm information to be displayed on the main screen

## Table 5 – System Settings

These parameters can be changed by the user.

No.	Parameter	Parameter Range	Default value	Comments
<b>Display Settings</b>				
5.0	Language	Chinese / English	English	
5.1	Display Accuracy	0 – 4	2	Number of decimal digits for real-time volume
5.2	Contrast	0 – 100%	50%	Adjust the display's contrast setting
<b>Modbus Settings</b>				
5.3	Modbus Address	1 – 247	8	

No.	Parameter	Parameter Range	Default value	Comments
5.4	Baud Rate	1200, 2400, 4800, 9600, 19200, 38400, 57600	9600	
5.5	Even-odd Check	None, Odd, Even	None	
5.6	Byte Swap	2-1 4-3, 3-4 1-2, 4-3 1-2, 1-2 3-4	2-1 4-3	
<b>HART Settings</b>				
5.7	Device Address	0 – 999999	000001	HART device identification number
<b>Password</b>				
5.8	User Password	000000 – 999999	200000	This password is used to modify user level parameters

## Parameters Set by Manufacturer

Some parameters are set by the manufacturer and can not be changed by the user. If you need change any of the these parameters, please contact Compressed Air Alliance.

- Table 6 – Accumulation
- Table 7 – Empty Pipe parameters
- Table 8 – Sensor parameters
- Table 9 – Test parameters

### Table 6 – Accumulation (set by manufacturer)

These parameters are set by the manufacturer.

No.	Parameter	Parameter Range	Default value	Comments
6.0	Accumulation Clearance	Y, N	N	These parameters are set by the manufacturer
6.1	Positive Accumulation Integer	0 - 999999999	0	
6.2	Positive Accumulation Decimal	0.0 – 0.999	0.0	
6.3	Negative Accumulation Integer	0 – 999999999	0	
6.4	Negative Accumulation Decimal	0.0 – 0.999	0.0	

## Table 7 – Empty Pipe Settings (set by manufacturer)

These parameters are set by the manufacturer.

No.	Parameter	Parameter Range	Default value	Comments
7.0	Empty Pipe Threshold Value	0 – 100%	50%	
7.1	Actual Electrical Conductivity	-	-	Displays the measured conductivity equivalent of the fluid
	For general natural water: <ul style="list-style-type: none"> <li>• equivalent &lt; 200 when the tube is full,</li> <li>• equivalent &gt; 1200 when the tube is empty</li> </ul>			
7.2	Empty Pipe Check Permission	Y, N	Y	Set whether to enable empty detection function
7.3	Empty Pipe Check Max	0 – 9999	1200	Measured conductivity equivalent value when the tube is empty.  Default values can be used for general natural water.
7.4	Empty Pipe Check Max	0 – 9999	200	Measured conductivity equivalent value when the tube is full
7.5	Empty Pipe Detection Backlash	0 – 9999	30	The return difference judged by the empty pipe detection

## Table 8 – Sensor Settings (set by manufacturer)

These parameters are set by the manufacturer.

No.	Parameter	Parameter Range	Default value	Comments
8.0	Sensor Coding	13 digits	-	Used for identify sensors
8.1	Factory ID Number	6 Digits	-	Identification number
8.2	Diameter	3 – 2000	50	Caliber of sensor
8.3	Zero Adjustment	-9.99 - 9.99mv	0.00mV	Sensor code value under the condition of static and full pipe (mean value of 30 seconds)
8.4	Sensor Coefficient	0 – 99999	-	The flowmeter coefficient was calibrated by the sensor manufacturer according to the actual flow volume
8.5	Cali Coefficient	-	-	Ex-factory unification calibration coefficient of converter
8.6	Zero Correction	0 – 99.999		For correcting the sensor's nonlinear correction for small flow (below 0.3 m/s)
8.7	Excitation Mode	3.125 Hz, 6.25 Hz, 12.5 Hz, 25 Hz	6.25 Hz	
8.8	Gain Selection	2001/3/9	X3	Adjustment of the gain can change the range of flow speed

**Table 9 – Test Parameters (set by manufacturer)**

These parameters are set by the manufacturer.

No.	Parameter	Parameter Range	Default value	Comments
9.0	Allow Test	Y, N	N	
9.1	Flow Rate	-99.999 ~ +99.999	1.000	
9.2	Source code	Y, N	N	

# Communication Settings

## Default Modbus Settings

The flow meter has the following default Modbus settings. Settings can be changed to suit system requirements.

Default Modbus RTU (RS485) Settings					
Address	Baud Rate	Frame / Parity / Stop Bit	Response Time	Response Delay	Frame Spacing
8	9600	8 / N / 1	1 Sec	0 Milliseconds	7 Characters

## Modbus Registers

Note: Float/ulong/long type data, Communication transmission is in byte order 2-1-4-3; ushort type data transmission is in accordance with 2-1.

Parameter	Type	Address	Comments
Real-time flow rate	Float	100	
Real-time flow velocity	Float	102	
Flow percentage	Float	104	50 stands for 50%
Electric conductivity	Float	106	
Forward flow accumulation of integer	ulong	108	
Forward flow accumulation of decimal	ulong	110	The decimal part magnifies by 100 times, 123 stands for 0.123
Reverse flow accumulation of integer	ulong	112	
Reverse flow accumulation of decimal	ulong	114	The decimal part magnifies by 100 times, 123 stands for



Parameter	Type	Address	Comments
			0.123
Instantaneous heat	Float	120	
Input temperature	Float	122	
Output temperature	Float	124	
Heat accumulation integer	ulong	126	
Heat accumulation decimal	ulong	128	The decimal part magnifies by 100 times, 123 stands for 0.123
Cooling cumulative integer	ulong	130	
Cooling Cumulative Decimals	ulong	132	The decimal part magnifies by 100 times, 123 stands for 0.123
Heat unit	ushort	134	0x00: kW 0x01: MW 0x02: kJ/h 0x03: MJ/h 0x04: GJ/h
Cumulative heat unit	ushort	135	0x00: kWh 0x01: MWh 0x02: kJ 0x03: MJ 0x04: GJ

## Communication Configuration

For 32-bit data (long plastic or floating point) arranged in the communication frame:

Example: Long integer 16909060(01020304H): 03 04 01 02

Floating number 4.00(40800000H): 00 00 40 80

# Warranty

Compressed Air Alliance provides a 12-month warranty for all sensors. The warranty covers materials and workmanship under the stated operating conditions from the date of delivery. Please report any findings immediately and within the warranty time.

If faults occur during the warranty period Compressed Air Alliance will repair or replace the defective unit, without charge for repair labour and material costs but there is a charge for other services such as labour to remove or reinstall the instrument, transport and packing. Warranty repairs do not extend the period of warranty.

The following damage is excluded from this warranty:

- Improper use and non-adherence to the user manual.
- Use of unsuitable accessories.
- External influences (e.g. damage caused by vibration, damage

during transportation, excess heat or moisture).

The warranty is cancelled when one of the following situations occurs:

- The user opens the measurement instrument without a direct request written in this manual.
- Repairs or modifications are undertaken by third parties or unauthorised persons.
- The serial number has been changed, damaged or removed.

Other claims, especially damage occurring on the outside of the instrument (eg dents, marks), are not included unless responsibility is legally binding.

# Calibration

The sensor is calibrated before delivery. The calibration date is printed on the certificate which is shipped with the sensor.

# Trouble Shooting

Problem	Possible Cause	Suggested Fix
Converter flow is negative	<ol style="list-style-type: none"> <li>1. The sensor is installed opposite to the fluid flow direction</li> <li>2. There is a reverse connection between SIG1 and SIG2 or EXT1 and EXT- in the sensor junction box</li> </ol>	<ol style="list-style-type: none"> <li>1. Remove flow meter and reinstall it in the opposite direction (ie, rotate the flow meter 180°)</li> <li>2. Re-wire the converter</li> </ol>
Converter output overrange	<ol style="list-style-type: none"> <li>1. The flow meter range value is less than the actual measurement value</li> <li>2. Fluid does not fill the pipe</li> <li>3. Exciter coil open circuit</li> </ol>	<ol style="list-style-type: none"> <li>1. Expand the flow meter range</li> <li>2. Close the small flow control valve</li> <li>3. Rewire</li> </ol>
The output signal fluctuates too much	<ol style="list-style-type: none"> <li>1. There is gas at the sensor electrode, resulting in poor contact between the electrode and the medium</li> <li>2. Deposits on the electrodes</li> </ol>	<ol style="list-style-type: none"> <li>1. Exclude the gas in the pipeline</li> <li>2. Clean the electrode</li> </ol>
The output signal gradually drifts towards zero	<ol style="list-style-type: none"> <li>The sensor enters the water</li> <li>2. Electrodes are covered</li> </ol>	<ol style="list-style-type: none"> <li>1. Replace the sensor</li> <li>2. Clean the electrode</li> </ol>

## Need help?

Contact your local dealer.

Alternatively, contact Compressed Air Alliance via:

- Phone (Australia): 1300 558 526
- E-mail: [sales@compressedairalliance.com](mailto:sales@compressedairalliance.com)
- Website: [www.compressedairalliance.com](http://www.compressedairalliance.com)



## Compressed Air Alliance Pty Ltd

Address: 2/7 Narabang Way, Belrose NSW 2085, Australia

E-mail: [sales@compressedairalliance.com](mailto:sales@compressedairalliance.com)

Website: [www.compressedairalliance.com](http://www.compressedairalliance.com)