



User Manual

Power Meter - Din Rail, with Display

Model: POM100x01



Table of Contents

Notices and Warnings.....	3
Introduction.....	4
Multi-Function Power Meter	5
Specifications	6
Installation	14
Installation.....	15
Installation Overview	16
Installation – Mechanical	16
Installation – Electrical	18
Configure the Power Meter.....	25
Operation.....	27
Using the Power Meter	28
Settings Menu	30
Measure Menu.....	38
Reset Menu	46
Device Information Menu.....	47
Trouble Shooting.....	48
Trouble Shooting.....	49
Warranty.....	51
Need help?	51

Notices and Warnings

Notices

Please **read all of this manual** before you install, operate or maintain this product. Pay attention to notes, warnings and instructions. The manufacturer cannot be held liable for any damage which occurs as a result of noncompliance with this manual.

Do not tamper with the product. Should the product be tampered with in any manner other than a procedure which is described and specified in this manual, the warranty is cancelled and the manufacturer is exempt from liability.

The product is designed exclusively for the application described in this manual. Use of this product in conditions not specified in this manual or, contrary to the instructions provided by the manufacturer, is considered improper handling of the product and will void the warranty. The manufacturer will not be held liable for any damages resulting from improper use of the product.

This manual should be read carefully by relevant personnel and the end user. This manual should be kept with the product and be made available as needed. **Once you install or use the product, you accept that you have read, understood and complied with this manual.**

Compressed Air Alliance endeavours to make the content of this manual correct, but is not responsible for omissions or errors and the consequences caused. If in doubt, or if you have any questions regarding this manual or the product, please contact Compressed Air Alliance.



Warnings

Ignoring warnings can lead to serious injury and/or cause damage!

When handling, operating or carrying out maintenance on this product, personnel must employ safe working practices and observe all local health & safety requirements and regulations.

Improper operation or maintenance of this product could be dangerous and result in an accident causing damage to machinery, personal injury or death.

The manufacturer cannot anticipate every possible circumstance which may represent a potential hazard. The warnings in this manual cover the most common potential hazards and are therefore not all-inclusive. If the user employs an operating procedure, an item of equipment or a method of working which is not specifically recommended by the manufacturer they must ensure that the product will not be damaged or made unsafe and that there is no risk to persons or property.

NEVER CHANGE ORIGINAL COMPONENTS WITH ALTERNATIVES.

Introduction

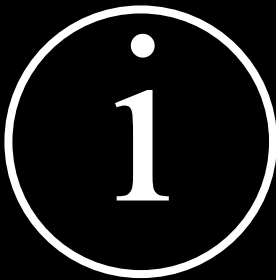

Multi-Function Power Meter

Intended use

Compressed Air Alliance's power meters are suitable for use in manufacturing, industrial and base building environments providing the power meter's specifications are met. This includes:

- Input (measured) voltage is less than 600 vAC
- Measured current is less than 10,000 Amps
- The power meter is used with external Rogowski coils or external CT (333mV only)
- The ambient operating temperature is between -25°C to +60°C (-13°F to +140°F).
- The power meter is not used in explosive areas.

Refer to the *Specifications* section (next page) for full requirements.

About the power meter

This multi-function, 3 phase, power meter measures voltage, amps, kilowatts, power factor, reactive power (kVa), total kilowatts, kilowatt hours and electrical system harmonics.

The power meter:

- can be used on 3 phase or single phase systems

- is simple to install via Din Rail mounting
- is easy to configure via the in-built display
- only requires 24vDC power supply
- can be connected into your data acquisition system
- can be installed on mains supply
- can be used for sub metering individual equipment or sub loads
- has Modbus/RTU output.

Why should you monitor power?

Monitoring power can help you:

- Reduce operating and energy costs
- Improve understanding of energy usage (eg spikes, variation, usage)
- Identify phase and voltage issues
- Identify power factor and harmonic issues
- Compare and challenge your energy bill
- Improve efficiency and reduce waste
- Monitor your mains power supply usage and quality
- Monitor individual equipment usage or sub system loads

Specifications

Power Meter Specifications

Power Meter Details	
Type	Multi-function power meter
Applications	Power analysis Tariff meter
Mounting	Din Rail
Poles Description	3PH4W (3 or 4 CT) 3PH3W (2 or 3 CT) 1PH3W 1PH2W
Connection	Screw terminals
Display	1.77 inch TFT screen display
Dimensions	94.5 mm L x 72.5 mm W x 66 mm D 3.7" L x 2.85" W x 2.6" D
Weight	259 grams
Colour	White
Installation Type	Permanent installation or temporary installation
Warranty	12 months
Operating Conditions	
Power Supply	24 VDC, 45- 60 Hz
Max Power Consumption	3.5 VA
Operating temperature	-25°C to +60°C -13°F to +140°F
Storage temperature	-40°C to +85°C -40°F to +185°F
Humidity rating	5% to 95% RH at 50°C (non-condensing)
IP degree of protection	IP20 conforming to IEC 60629

Pollution degree	2: Normally only nonconductive pollution occurs. Temporary conductivity caused by condensation is to be expected.	
Altitude	3000m Max	
Overvoltage category	CAT III 1000V It is suitable for distribution systems below 277 / 480vAC	
Dielectric withstand	As per IEC61010-1, Doubled insulated front panel display	
Insulation Strength	IEC61010-1	
Accuracy		
Accuracy Note: The accuracy of the power meter is affected by the quality of installation. On-site conditions such as oil, high humidity or other impurities can also affect the accuracy of the power meter	Current	±0.1% + accuracy of current sensor
	Rated current	500A (0.5% from 10A to 600A) 3,000A (0.5% from 30A to 3600A) 10kA (0.5% from 100A to 12kA)
	Rogowski coil specification	±0.5% (85mV/kA@50Hz)
	Voltage	±0.2% (60V to 600V AC)
	Grid Frequency	±0.01% (45-65Hz)
	Power factor	±0.005
	Active/Apparent Power	IEC62053-22 Level 0.5S
	Reactive power	IEC62053-21 Level 1S
	Active energy	IEC62053-22 Level 0.5S
	Reactive energy	IEC62053-21 Level 1S
Input		
Input type	External CT (333mV only) or External Rogowski coil (500A or 1,000A or 3,000A)	
Current - Channel Input Voltage Range	0-900 mVAC peak, 636 mV RMS	
Current - VCT	0 – 99999 A	

Voltage - Channel Input Voltage Range	0~600 VAC Phase Voltage
Voltage - Maximum range	720 VAC Phase Voltage
Digital input	One way dry contact input, optocoupler isolation (5kVrms)
Output	
Output parameters	Voltage, Amps and Kilowatts for each phase, power factor, reactive power (kVa), total Kilowatts, Kilowatt hours and electrical system harmonics
Relay Output	One way electromagnetic relay output Contact capacity: 3A 30V DC, 3A 250V AC
Communication	Modbus RS485
EMC	
Electrostatic discharge	Level IV (IEC61000-4-2)
Radiated immunity	Level III (IEC61000-4-3)
EFT Electrical fast burst immunity	Level IV (IEC61000-4-4)
Surge immunity	Level IV (IEC61000-4-5)
Conducted disturbance immunity	Level III (IEC61000-4-6)
Power frequency magnetic field immunity	0.5mT (IEC61000-4-8)
Conduction and radiation	Class B (EN55022)
Standard compliance	
EN 62052-11, EN61557-12, EN 62053-21, EN 62053-22, EN 62053-23, EN 50470-1, EN 50470-3, EN 61010-1, EN 61010-2, EN 61010-031	

Communication Specifications

Communication	
Transmission mode	One way RS485 communication interface
Interface type	2 wire, Half duplex
Communication protocol	MODBUS RTU
Settings	
Communication address	1 to 247 (default 1)
Baud rate	2400 to 38400 baud (default 19200)
Parity	Even, Odd, None (default)
Data Bit	8
Stop bit	1

Data Display Specifications

Instantaneous Values	
Phase Voltage	U1, U2, U3, AVG
Line Voltage	U12, U23, U31, AVG
Current	I1, I2, I3, AVG, IN
Grid Frequency	F1, F2, F3, Σ
Power Factor (PF)	PF1, PF2, PF3, Σ
Fundamental power factor (DPF)	DPF1, DPF2, DPF3, Σ
Active power	P1, P2, P3, Σ
Reactive power	Q1, Q2, Q3, Σ
Apparent power	S1, S2, S3, Σ

Energy	
Active energy Pos.	EP1, EP2, EP3, Σ
Active Energy Neg.	EP1, EP2, EP3, Σ
Reactive Energy Pos.	EQ1, EQ2, EQ3, Σ
Reactive energy Neg.	EQ1, EQ2, EQ3, Σ
Apparent Energy	ES1, ES2, ES3, Σ
Tariff Energy	ET1, ET2, ET3, ET4, ET5, ET6
Harmonics	
Voltage Harmonic Distortion	THD (Total harmonic percentage), TOHD (Odd total harmonic percentage), TEHD (Even total harmonic percentage), phase L1. L2. L3 1-50th harmonic percentage, phase ABC 1-50th harmonic voltage value
Voltage Harmonic Value	
Current Harmonic Distortion	THD (Total harmonic percentage), TOHD (Odd total harmonic percentage), TEHD (Even total harmonic percentage), phase L1.L2.L3 1- 50th harmonic percentage, phase ABC 1-50th harmonic current value
Current Harmonic Value	
Phasor diagram	
Phasor diagram	between voltage and current
Phase Sequence	voltage and current
Voltage Angle	U1, U2, U3
Current Angle	I1, I2, I3
UI Angle	UI1, UI2, UI3
Demand	
Demand	P, Q, S
Active power DMD Max	P and Time
Reactive power DMD Max.	Q and Time
Apparent power DMD Max.	S and Time

Unbalance	
Voltage unbalance	Negative Sequence, zero Sequence
Current unbalance	Negative Sequence, zero Sequence
Max & Min	
Phase Voltage	U1, U2, U3, AVG
Line Voltage	U12, U23, U31, AVG
Current	I1, I2, I3, AVG, IN
Active power	P1, P2, P3, Σ
Reactive power	Q1, Q2, Q3, Σ
Apparent power	S1, S2, S3, Σ

Power Meter Dimensions

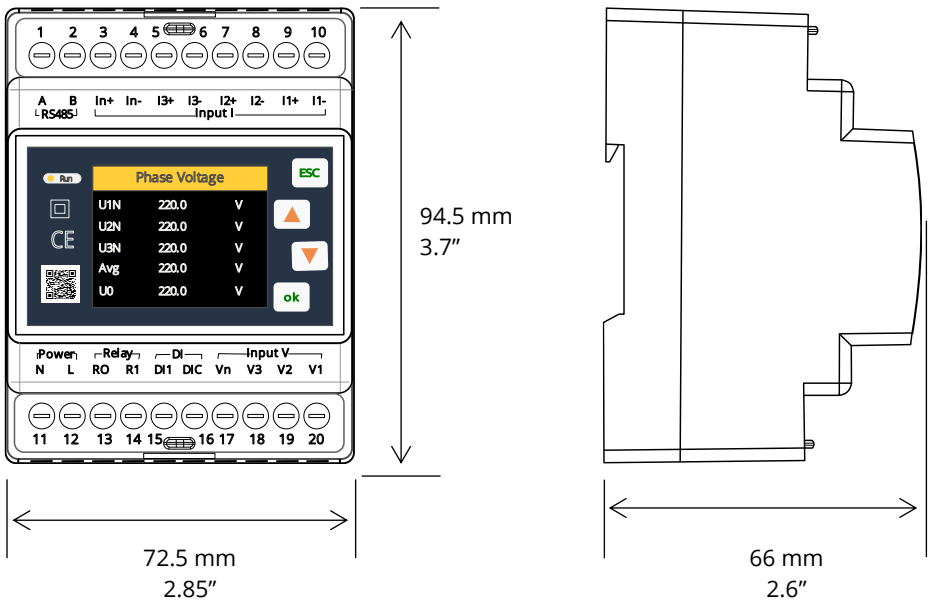

Rogowski Coil Specifications

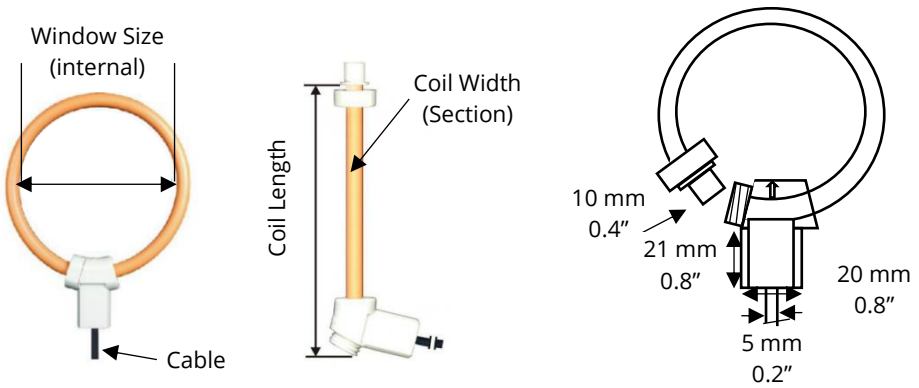

	500 Amps	1,000 Amps	3,000 Amp
Rated Current	500 A	1,000 A	3,000 A
Coil Resistance	140 (± 10) Ω	210 (± 10) Ω	290 (± 10) Ω
Window Size (Internal)	50 mm or 1.97"	100 mm or 3.94"	150 mm or 5.91"
Coil Length	200 mm or 7.87"	350 mm or 13.78"	510 mm or 20.08"
Coil Width (Section)	8 mm		
Cable Length	5 meters		
Weight	140 g	150 g	160 g
Ratio	Calibrated:	85mV / kA@50Hz	
	Uncalibrated:	110mV / kA@50Hz	
Read Accuracy	Calibrated:	<0.5% (central position, 25°C)	
	Uncalibrated:	< 5% tolerance (central position, 25°C)	
Maximum Current Measurable	100kA		
Position Error	±1% maximum		
Output on 0A (zero drift)	≤0.05 mV		

Phase error	$\leq 0.5^\circ$	
Linearity	$\pm 0.2\%$ reading	
Bandwidth	1Hz to 100 Hz (-3db)	
Shielded	100% coil, 100% output cable	
Voltage Insulation	Coil: 3,000V Signal cable: 1,000V	
Compliance	LVD EN 61010-1:2010 EMC EN 61326-1:2013	
Safety	1000V CATIII ,600V CATIV	
Materials	Coil & cable	Thermoplastic rubber, flame retardant UL 94 V-0 rated
	Couplings	PA6 UL 94 V-O rated
Operation Temperature	-30°C to +80°C	-22°F to 176°F
Storage Temperature	-40°C to +90°C	-40°F to 194°F
Installation Type	Temporary or permanent installation	
Warranty	12 months	

Rogowski Coil Position Sensitivity



Conductor Position		Typical Error (%)
●	Adjacent to the center of coil	0.2%
●	Adjacent to the inside coil	<1%

Installation

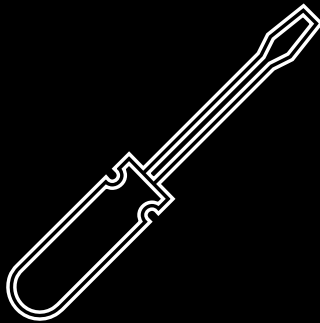

Installation



WARNING! Risk of electrical shock.

Any contact with energised parts of the product, may lead to an electrical shock, serious injuries or even death. The user shall take all measures necessary to protect against electrical shock.



Notes

- Users should be suitably qualified, licensed and experienced to install, operate, maintain and remove this product.
- Please follow local and national regulations before/during installation and operation.
- **Before installing the product, make sure it is rated for your system** (refer to the “Specifications” section).
 - Use of the product outside specified ranges or operating parameters can lead to malfunctions and may damage the product or system.
- The system must be disconnected from any power supply during installation, maintenance and removal work.
- Certain parts of the product may carry hazardous live voltage (e.g. primary conductor). The user shall take all measures necessary to protect against electrical shock. A protective enclosure or additional insulation barrier may be necessary.
- Do not use this product in explosive areas.
- Do not stress the Rogowski Coils by applying any kind of mechanical force (i.e. twisting, puncturing, excessive pressure, tight bending, etc.) as this will dramatically degrade the device’s accuracy.
- Do not disassemble the product.
- The product must be installed properly, otherwise it may lead to inaccurate measurement values.
- The product should be maintained and checked for faulty wiring on a regular basis.
- **Incorrect installation can damage the product, cause it to work incorrectly or result in injury or death.**

Installation Overview

Step 1 – Attach Power Meter to din rail

Step 2 – Attach Rogowski coils around wires

Step 3 – Wire Rogowski coils, 24vDC power supply and Modbus communication cable to power meter

Step 4 – Set up the power meter

Installation – Mechanical

Installation and maintenance must be done with the main power supply disconnected. Please observe local and national regulations.

Step 1 – Clip power meter to din rail.

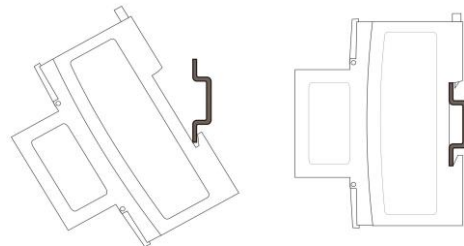

Step 2 - Attach Rogowski coils around wires (see diagram below)

- 1 - Locate clip on the Rogowski Coil base unit
- 2 - Unscrew clip and pull out coil from base unit
- 3 - Place coil over conductor, ensuring arrow faces toward the load
- 4 - Insert coil back into base unit and screw clip to secure the coil

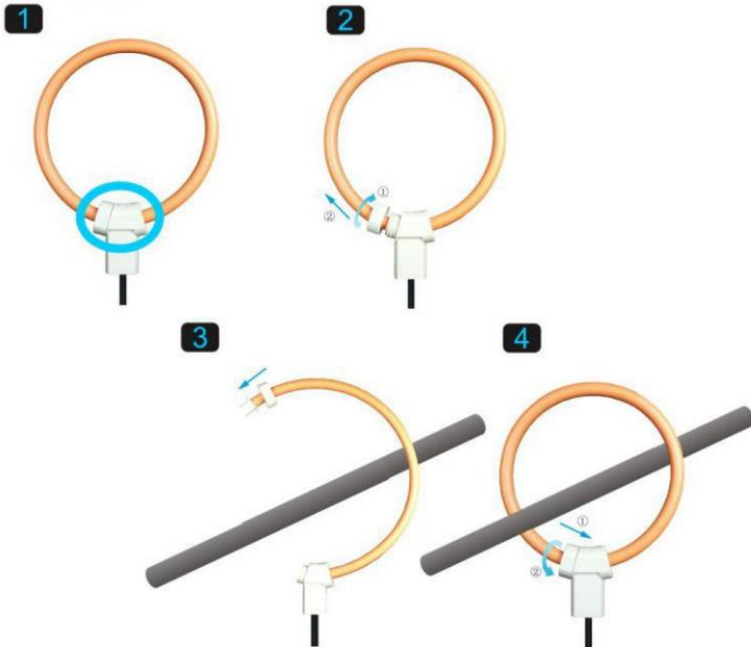

Installation – Electrical



WARNING! Risk of electrical shock

Incorrect wiring or contact with energised parts of the product, may lead to an electrical shock which can lead to serious injuries or even death. The user shall take all measures necessary to protect against electrical shock.



Notes:

- Always check the wires to make sure they are wired correctly.
- Consider all local and national safety requirements and regulations for electrical installations.
- **The system must be disconnected from any power supply during installation and maintenance work.**
- Any electrical work on the system is only allowed by authorised and qualified personal.

Port Definition

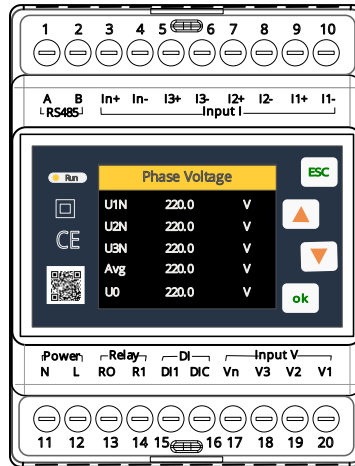

Port Number	Port Name	Port Function	Remarks
1	A	RS485 A (Data +)	RS485 communication
2	B	RS485 B (Data -)	
3	In+	Phase N current input positive	Current Input Current channels
4	In-	Phase N current input negative	
5	I3+	Phase L3 current input positive	
6	I3-	Phase L3 current input negative	
7	I2+	Phase L2 current input positive	
8	I2-	Phase L2 current input negative	
9	I1+	Phase L1 current input positive	
10	I1-	Phase L1 current input negative	
11	N	Power supply (-)	Power supply 24vDC
12	L	Power supply (+)	
13	RO	Relay common contact	Relay output

Port Number	Port Name	Port Function	Remarks
14	R1	Relay normally open contact	One relay output with normally open
15	DI1	Digital input channel 1	Digital input
16	DIC	Digital channel common terminal	ONE way dry contact input
17	Vn	N-phase voltage input	Voltage input
18	V3	L3-phase voltage input	Measurement voltage input channel
19	V2	L2-phase voltage input	
20	V1	L1-phase voltage input	

Wiring Diagrams



WARNING: Incorrect wiring and installation can cause an electric shock, electrocution or damage to the power meter or other equipment. It may also void the warranty.

Notes:

- The phase sequence of voltage and current must follow the phase sequence of ABC, otherwise the meter will display the phase sequence error of voltage and current.
- When using the current sensor, the direction of the current arrow on the sensor must be consistent with the actual current flow direction.

Modbus Communication Wiring Diagram

The power meter is equipped with a RS485 communication interface, which supports Modbus RTU protocol.

The RS485 communication port requires a shielded twisted pair connection, which is connected in the form of daisy chain.

In the case of long distance and high speed connections, a 120 Ω resistor should be parallel connected at both ends of the daisy chain.

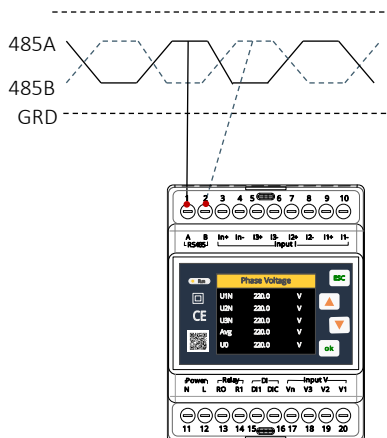

3 phase, 4 wire (3P4W) – 4CT

3P4W - 4CT requires 4 current sensors. The N phase current is measured by the sensors.

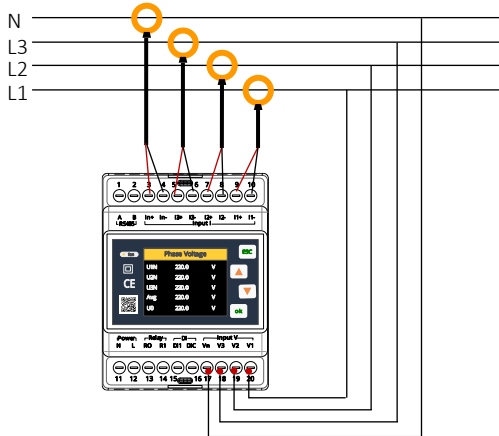

3 phase, 4 wire (3P4W) – 3CT

3P4W - 3CT requires 3 current sensors. The N phase current is obtained by calculation.

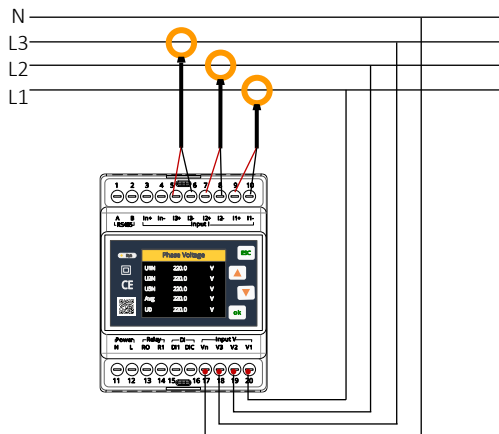

3 phase, 3 wire (3P3W) – 3CT

3P3W - 3CT requires 3 current sensors. The L2 phase current is measured by the sensors.

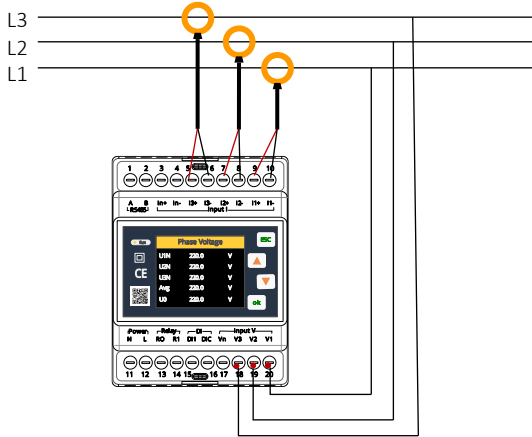

3 phase, 3 wire (3P3W) – 2CT

3P3W - 2CT requires 2 current sensors. The L2 phase current is obtained by calculation.

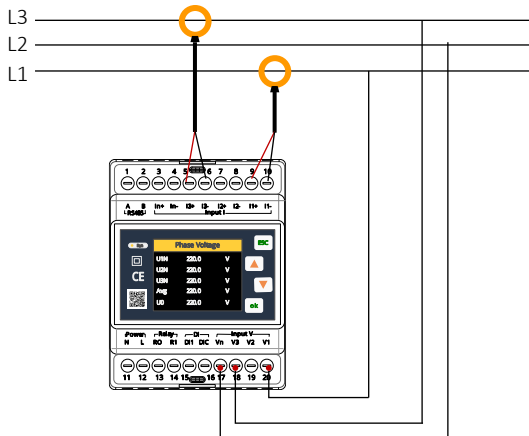

1 phase, 3 wire (1P3W) – 2CT

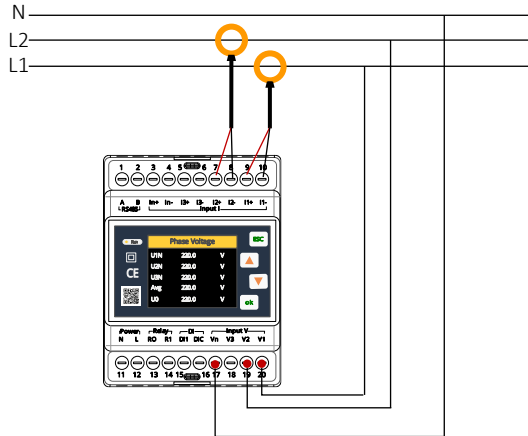

1 phase, 2 wire (1P2W) – 1CT

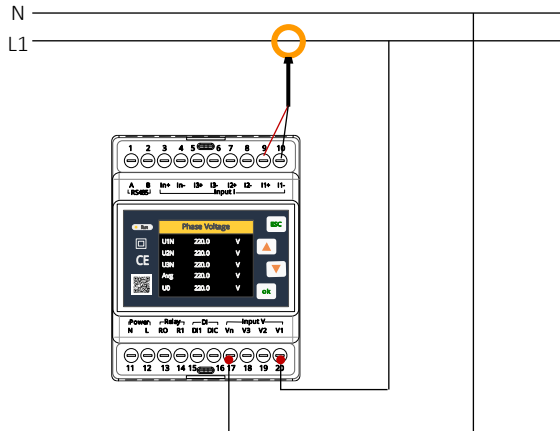

Configure the Power Meter

Before using the power meter, you **must configure it for your system**.

If you change the Rogowski Coils size or type of current sensors, then you must reconfigure the Current Sensor settings accordingly.



Note: Incorrect settings will result in incorrect data.

The table below shows the settings that must be configured. Other settings may also need to be configured. You need a password to access the Settings Menu.

- **Default password for the setting menu: 1000**
- If you change the password and then forget it, enter the last four digits of the device serial number to enter the Settings menu.

Setting	Options	Menu Location
Wiring and Power Settings		
Wiring Type	3P4W 4CT, 3P4W 3CT, 3P3W 3CT, 3P3W 2CT, 1P3W, 1P2W	Settings > Power Grid
Frequency	50 or 60 Hz	
Nominal Voltage	00001-65535 V	
VT Ratio	1~10000	
CT Ratio	1~10000	
Rogowski Coil Settings		
Current Phases	I1, I2, I3 or In	Settings > Current Sensor
Current Sensor Type	Rcoil (Rogowski Coil)	
Rated Current of Rogowski Coil	500, 1,000 or 3,000 Amps	

Setting	Options	Menu Location
Secondary Output of Rogowski Coil	85	
Modbus Settings		
Modbus Status	Enabled or Disabled	Settings > Communication
Device ID	000-247	
Baud rate	2400, 4800, 9600, 19200, 38400	
Parity	None, Odd, Even	
Stop Bits	1 or 2	
Optional Settings		
Demand Method	Fixed or Sliding	Settings > Demand
Demand Interval	1-60 minutes (15 minutes is the default option)	
Tariff details		Settings > Tariff
System Time	Year / month / day time: minutes: seconds	Settings > HMI

Operation

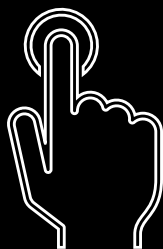

Using the Power Meter

HMI / Display

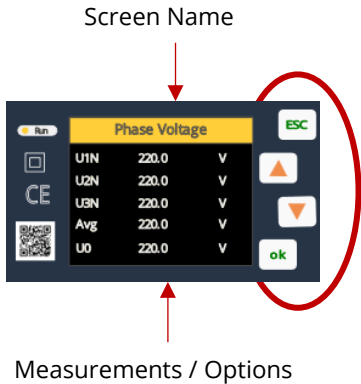

ESC button - exit the current operation / screen.

Up and Down buttons:

- Short Press: move up or down. Move between screens
- Long press: move left or right

OK button- confirm the selection. Switch the numerical display

Menu Options

The power meter has four main menus:

- **Settings** - set Modbus, Wire Type. Current sensor type, display settings, language, etc
- **Measure** - displays instantaneous and other data
- **Reset** - reset data / factory reset the power meter
- **Device information** - eg serial number of the power meter, firmware version.

Menu Structure

- Press the **ESC** or **OK** buttons to move between menus and sub-menus.
- Press the **Up** or **Down** button to move between options within a menu.

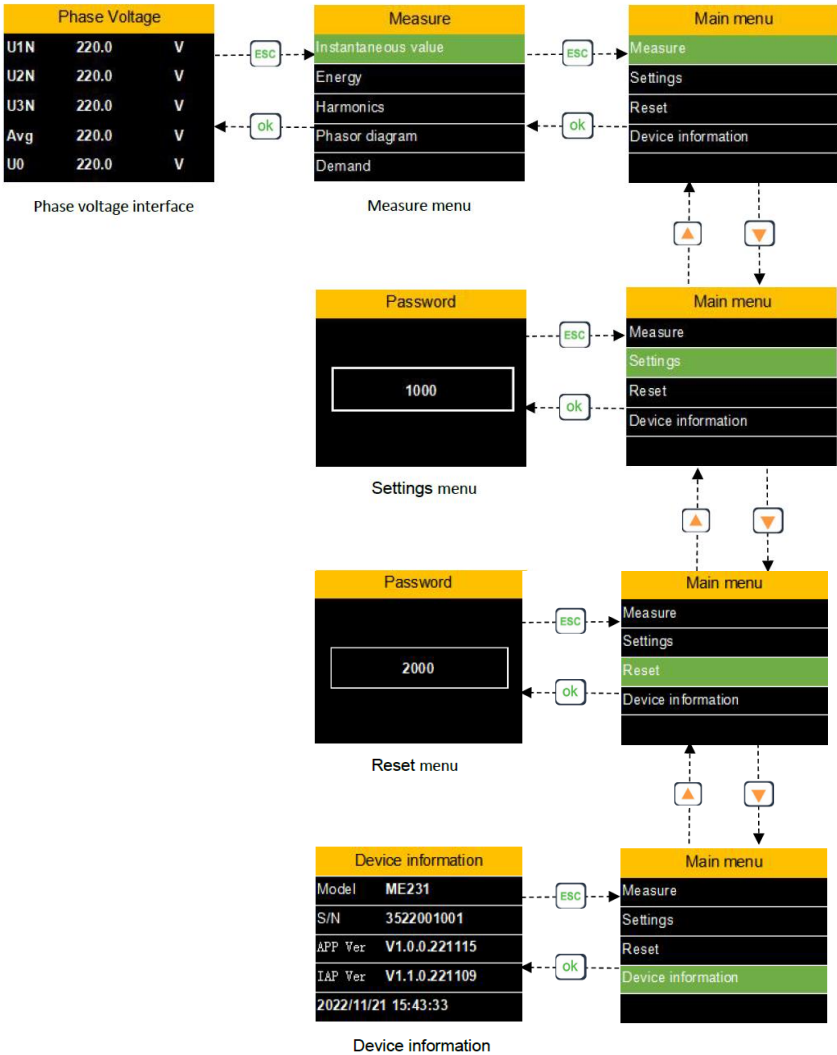

Settings Menu

The Settings Menu options are used to configure the power meter. At a minimum, you must check / set the following information before using the power meter. You must also update the Current Sensor information if you change Rogowski Coil size.

- Wire Type (eg 3P3W_3CT)
- Frequency (eg 50Hz)
- Nominal Voltage (eg 240VAC)
- VT and CT ratio (eg 1.0)
- Current sensor type (eg 1,000 Amp Rogowski Coil)
- Modbus RS485 settings (device ID, baud rate, parity, stop bits)

Password

You need to enter a password to access the power meter settings.

Default password for Settings menu = 1000.

Forgot your password? Enter the last four digits of the device serial number to enter the Settings menu.

To enter the password:

- Press the **OK** button
- **Short press** the **Up** or **Down** button to change the number
- **Long press** the **Up** or **Down** to move left or right (to select the previous / next number). Short press up / down to change the number. Repeat for all digits
- Once the password is correct, press the **OK** button.
 - If the password is correct, you will see the Settings screen
 - If the password is incorrect, you will stay on the Password screen.



Settings > Power Grid

The **Power Grid** sub-menu sets the Wiring Type, Frequency, Nominal Voltage, VT ratio and CT ratio.

- **Wire Type:** 3P4W 4CT, 3P4W 3CT, 3P3W 3CT, 3P3W 2CT, 1P3W, 1P2W
- **Frequency:** 50 or 60
- **Nominal Voltage:** 00001-65535
- **VT ratio:** 1~10000
 - (primary end voltage / secondary end voltage)*10000.Unit V/V
- **CT ratio:** 1~10000
 - (primary end current / secondary end current)*10000.Unit A/A.

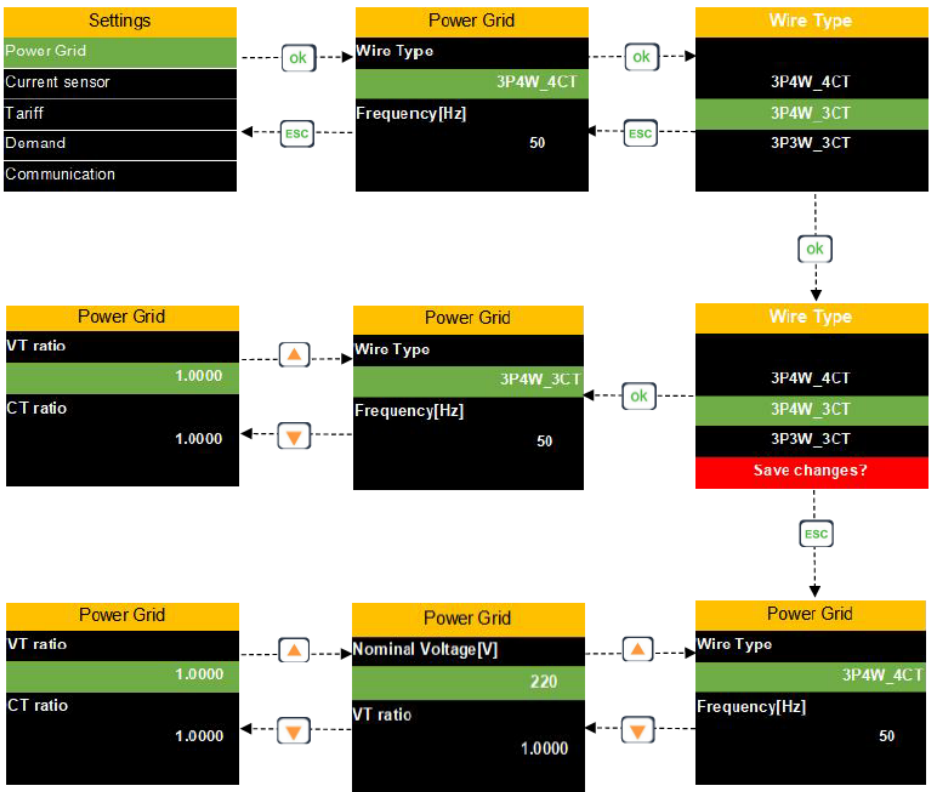

Settings > Current Sensor

The **Current Sensor** sub-menu sets the type of current sensor you will use.

- **Phase Type:** I1, I2, I3 or In
- **Sensor Type:** Rcoil (Rogowski coil) or VCT (Voltage output type CT)
- **Rated current of Rogowski coil (Pr[A]):** 500, 1000 or 3000
- **Nominal Current:** (the actual measured rated current value): 500, 1000 or 3000
- **secondary output value corresponding to the rated primary current (Sec[mV]@50Hz:** 85



Note: If you replace the Rogowski Coil with different size or ratio, the Pri/Sec must be reset.

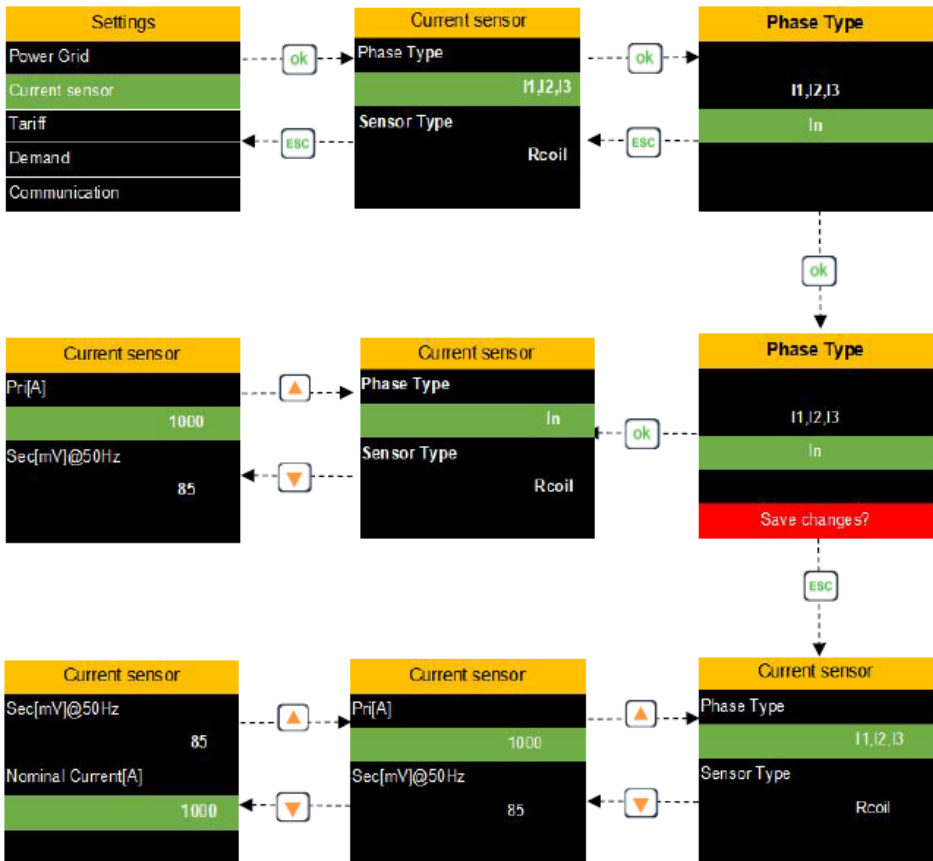

Settings > Demand

The **Demand** sub-menu sets the Calculation Method and Calculation Interval (in minutes).

Calculation method

- Fixed: updates the demand according to the calculation interval
- Sliding type: updates the demand once a minute

Calculation interval (minutes)

- Range: 1-60 minutes
- Default: 15 minutes



Settings > Communication

The **Communication** sub-menu sets the Modbus RS485 settings.

Status: Enable or Disable

Device ID (Address): 000-247 (default = 1)

Baud rate[bps]: 2400, 4800, 9600, 19200, 38400 (default = 19200)

Parity: None, Odd, Even (default = None)

Stop bits: 1 or 2 (default = 1)

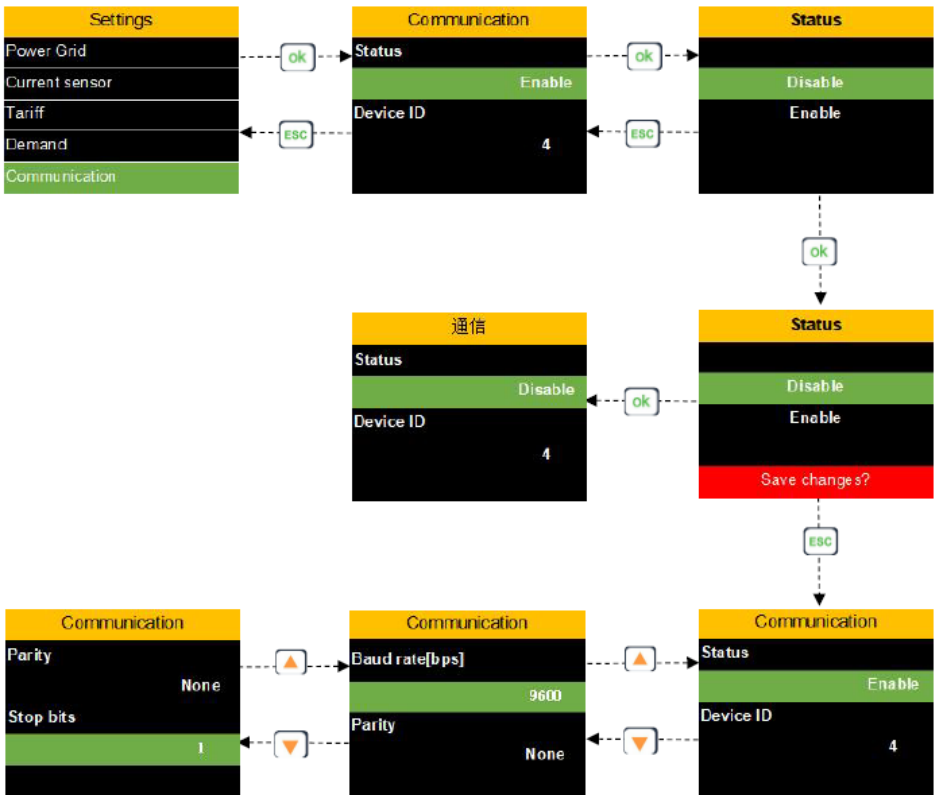

Settings > HMI

The **HMI** sub-menu sets the Language, Clock, Key Tone and Backlight Brightness.

Language: English or Chinese

Clock: Year / month / day time: minutes: seconds

Key Tone: Enable or Disable

Backlight OFF: Never, 1 minute, 2 minutes, 3 minutes, 4 minutes, 5 minutes

Backlight Brightness: 1-5

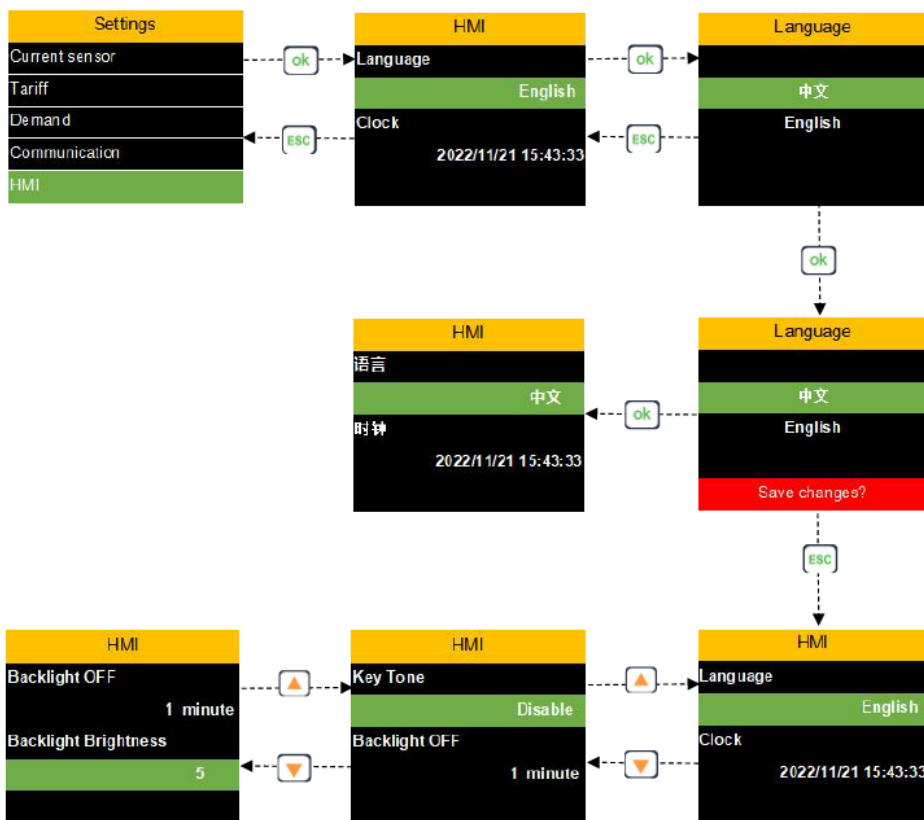

Settings > Password

The **Password** sub-menu allows you to change the settings menu and/or reset menu password.

Settings password: 0001-9999 (default = 1000)

Reset password: 0001-9999 (default = 2000)

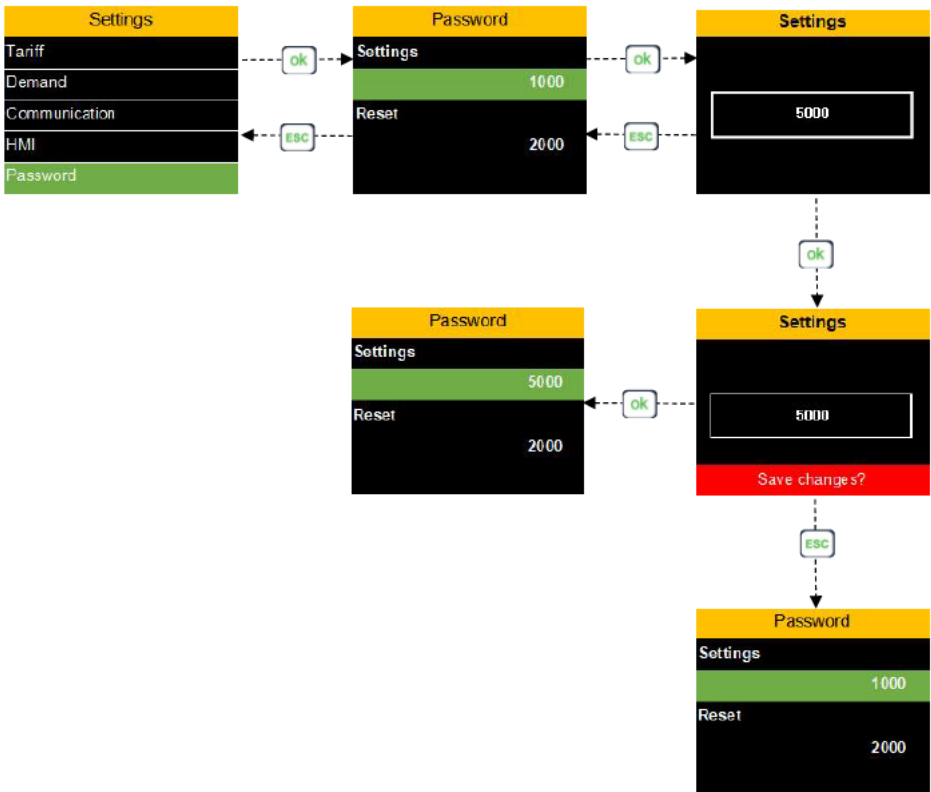

Measure Menu

The Measure Menu displays data and other information. It has 7 sub-menus:

- **Instantaneous Value** – eg instantaneous voltage, current, power readings
- **Energy** – eg active, reactive, apparent and tariff energy
- **Harmonics** – eg voltage harmonics, current harmonics and distortion
- **Phase Diagram** – eg display phasor diagram, Phase Sequence Angle
- **Demand** - eg display active power, reactive power, apparent power DMD
- **Imbalance** – eg voltage unbalance and current unbalance
- **Max. & Min.** – eg Voltage Max. & Min., Current Max. & Min.



Measure Menu > Instantaneous Value

The **Instantaneous Value** screens display voltage, current, power, power factor, frequency and other data (as shown below).

- To **move between screens**, press the **up** or **down** button.
- To return to the **Measure Menu**, press the **ESC** button once.
- To return to the **Main Menu**, press the **ESC** button twice.



Measure Menu > Energy

The **Energy** screens display active energy, reactive energy, apparent energy and tariff energy.

- To **move between screens**, press the **up** or **down** button.
- To return to the **Measure Menu**, press the **ESC** button once.
- To return to the **Main Menu**, press the **ESC** button twice.

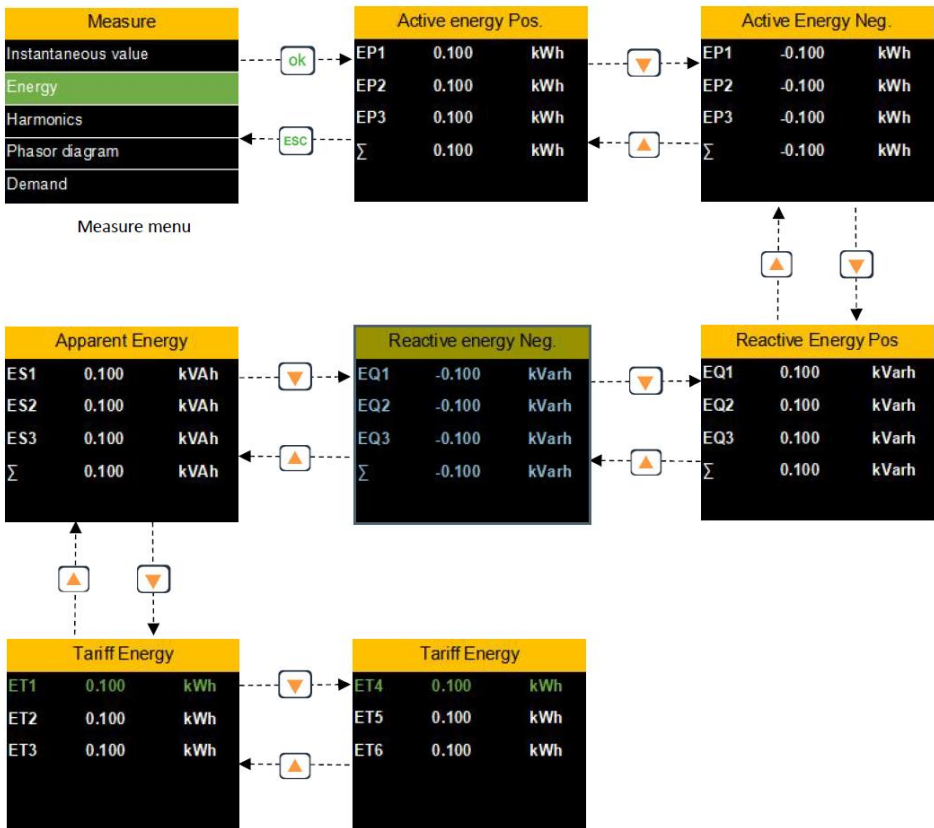

Measure Menu > Harmonics

The **Harmonics** screens display voltage harmonics, voltage distortion, current harmonics and current distortion.

- To **move between screens**, press the **up** or **down** button.
- To return to the **Measure Menu**, press the **ESC** button once.
- To return to the **Main Menu**, press the **ESC** button twice.

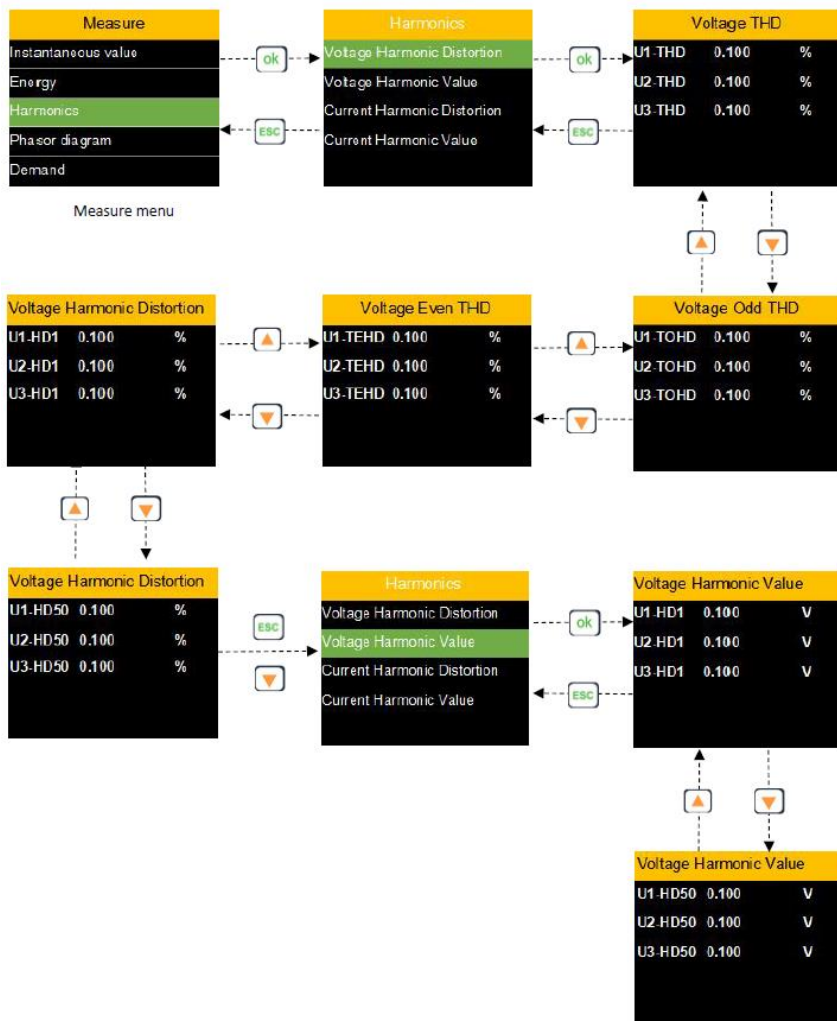

Measure Menu > Phasor diagram

The **Phasor diagram** screens display phasor diagram, Phase Sequence Angle and other data as shown be

- To **move between screens**, press the **up** or **down** button.
- To return to the **Measure Menu**, press the **ESC** button once.
- To return to the **Main Menu**, press the **ESC** button twice.

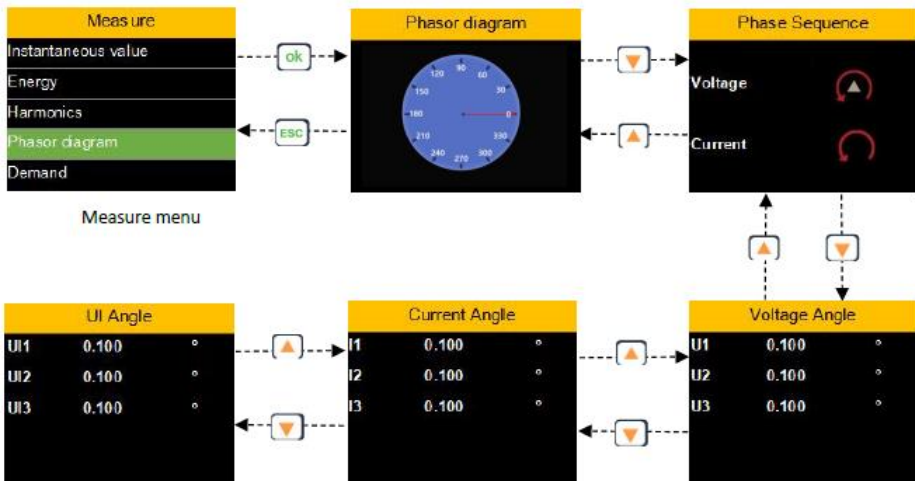

Measure Menu > Demand

The **Demand** screens display demand, active power DMD Max, reactive power DMD Max and apparent power DMD Max

- To **move between screens**, press the **up** or **down** button.
- To return to the **Measure Menu**, press the **ESC** button once.
- To return to the **Main Menu**, press the **ESC** button twice.

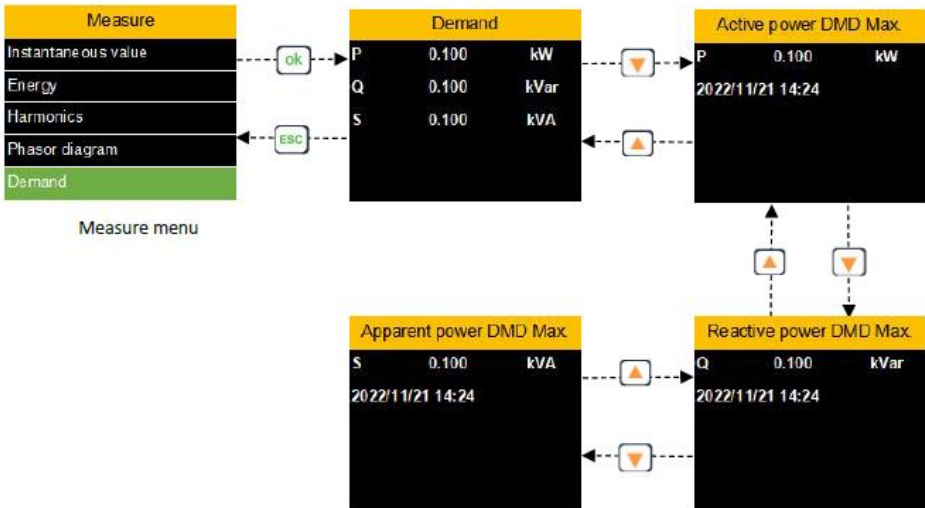

Measure Menu > Unbalance

The **Unbalance** screens display voltage unbalance and current unbalance.

- To **move between screens**, press the **up** or **down** button.
- To return to the **Measure Menu**, press the **ESC** button once.
- To return to the **Main Menu**, press the **ESC** button twice.



Measure Menu > Max. & Min.

The **Max. & Min.** screens display Voltage Max. & Min., Current Max. & Min.

- To **move between screens**, press the **up** or **down** button.
- To return to the **Measure Menu**, press the **ESC** button once.

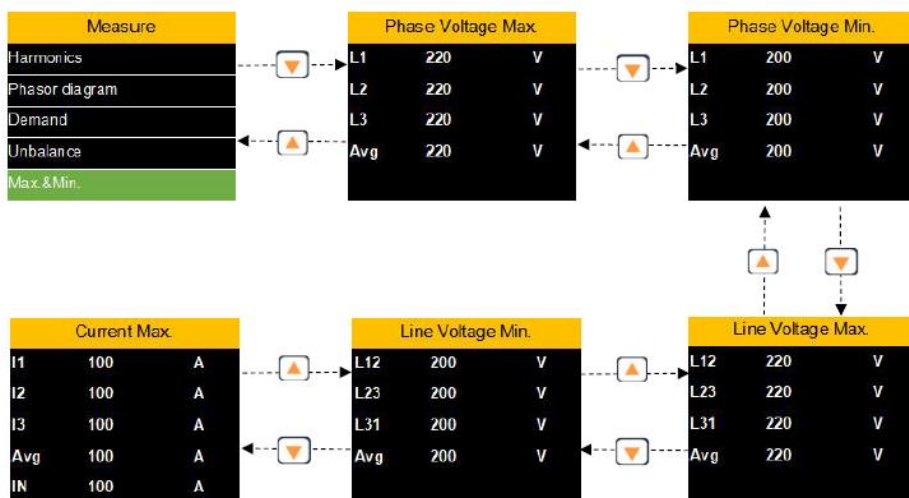

(Max. & Min. screens continued)

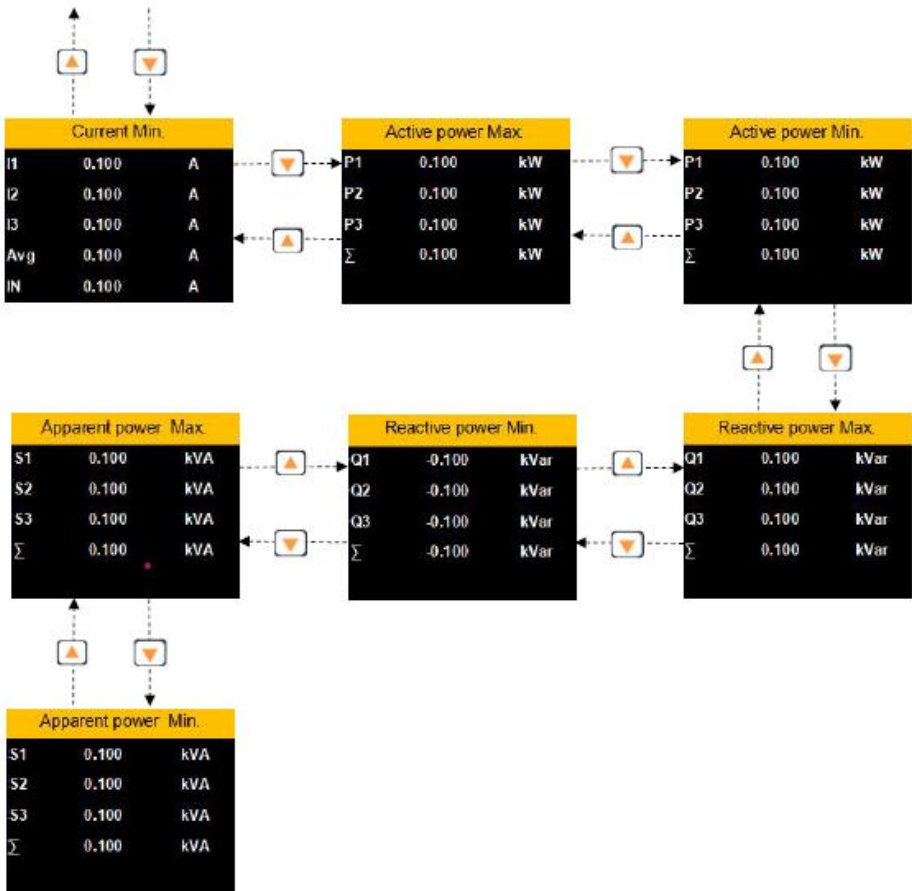

Reset Menu

The Reset Menu is used for resetting Max.Min., Demand Max., Tariff Energy, Energy and Factory Set.

You need to enter a password to reset the power meter.

Default password = 2000.

Forgot your password? Enter the last four digits of the device serial number to enter the Reset menu.

To enter the password:

- Press the **OK** button
- **Short press** the **Up** or **Down** button to change the number
- **Long press** the **Up** or **Down** to move left or right (to select the previous / next number)
- Once the password is correct, press the **OK** button.
 - If the password is incorrect, you will stay on the Password screen.

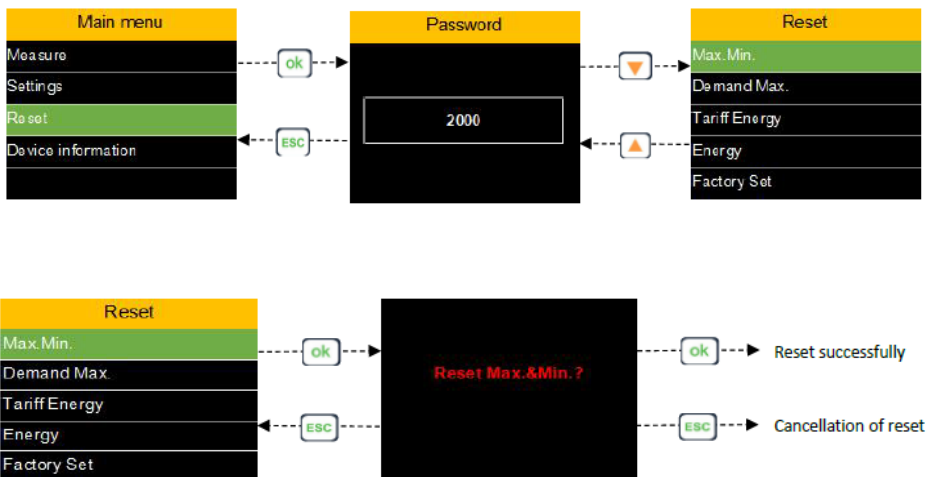

Device Information Menu

The device information menu is used to display: Device model, S/N, Firmware, Communication, Power grid parameters, and other data.

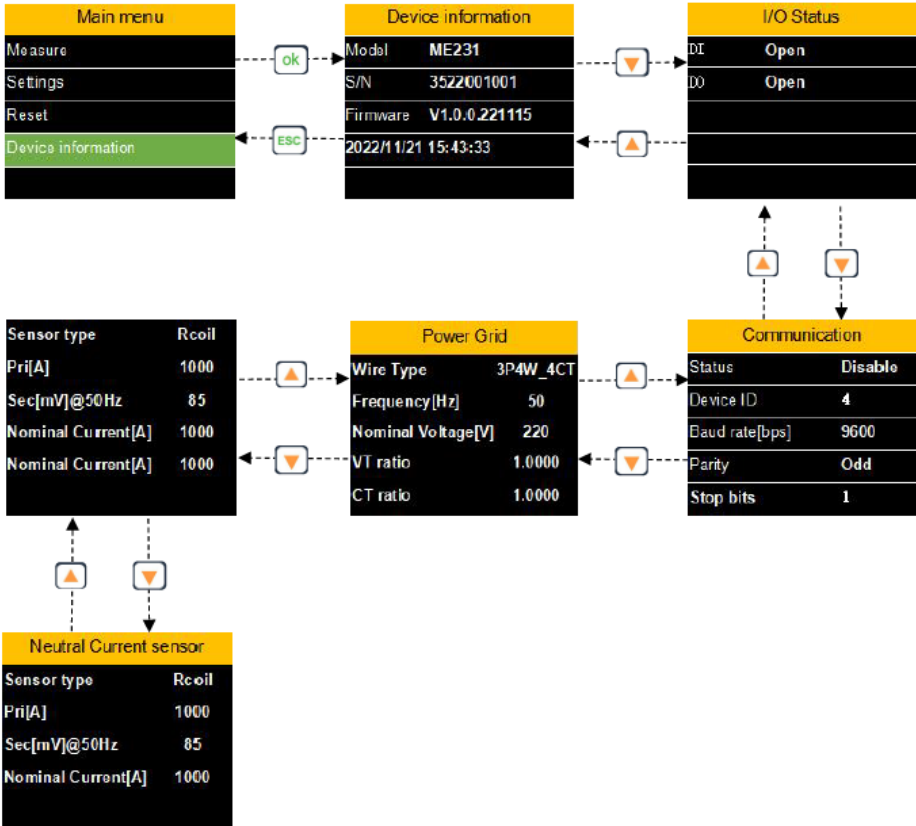

Trouble Shooting



Trouble Shooting

Problem	Suggested Action
I forgot the password	The default password for the Settings menu is: 1000
	<p>The default password for the Reset menu is: 2000</p> <p>If the default passwords don't work, use the last four digits of the power meter's serial number</p>
Readings are wrong	Check the specification of the Power Meter and Rogowski Coils meet your requirements
	<p>Check the Rogowski Coils were installed the right way around.</p> <ul style="list-style-type: none"> The arrow on the Rogowski Coil follows the direction of current flow
	<p>Check wiring on power meter is correct</p> <ul style="list-style-type: none"> Make sure you wired the phases correctly Make sure the Wiring information in "Settings > Power Grid" matches the actual wiring set up RS485 communication port requires a shielded twisted pair connection
	<p>Check the Power meter configuration. In particular, check:</p> <ul style="list-style-type: none"> Settings > Power Grid Settings > Current Sensor Settings > Communication (Modbus RS485 settings)
	Check that you are reading the correct Modbus addresses on your output display / energy management system
	Do a factory reset of the power meter (see Reset Menu for more information)
If you still have problems, contact Compressed Air Alliance or your local distributor.	

The screen is in the wrong language

Step 1 - From the Home Screen:

- Press the ESC button
- Press the ESC button again

This will take you to the **Main Menu** (see picture below)

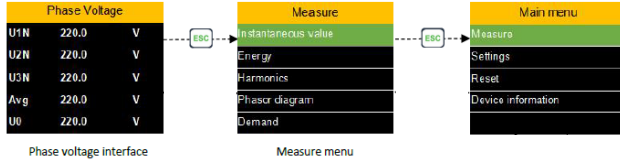

Step 2 - In the Main Menu:

- select the 2nd option from the top
- Enter your password (default password = 1000, or use the last 4 digits of the power meter's serial number)

This will take you to the **Settings Menu**



Step 3 - In the Settings Menu:

- select the 2nd option from the bottom (HMI)
- Highlight the top option (Language) then click OK
- Use the up or down buttons to select your language (English or Chinese), then press OK.
- Press OK (again) to save your setting

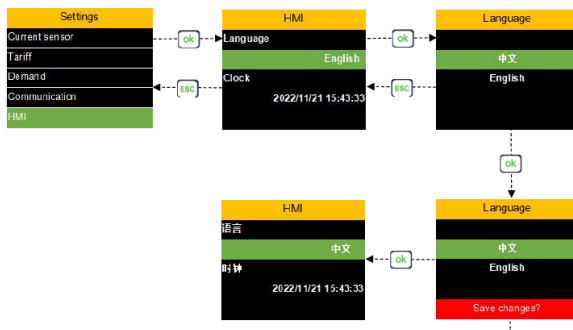

Warranty

Compressed Air Alliance provides a 12-month warranty for all Power Meters. The warranty covers materials and workmanship under the stated operating conditions from the date of delivery. Please report any findings immediately and within the warranty time.

If faults occur during the warranty period Compressed Air Alliance will repair or replace the defective unit, without charge for repair labour and material costs but there is a charge for other services such as labour to remove or reinstall the instrument, transport and packing. Warranty repairs do not extend the period of warranty.

The following damage is excluded from this warranty:

- Improper use and non-adherence to the user manual.
- Use of unsuitable accessories.
- External influences (e.g. damage caused by vibration, damage during transportation, excess heat or moisture).

The warranty is cancelled when one of the following situations occurs:

- The user opens the measurement instrument

without a direct request written in this manual.

- Repairs or modifications are undertaken by third parties or unauthorised persons.
- The serial number has been changed, damaged or removed.

Other claims, especially damage occurring on the outside of the instrument (eg dents, marks), are not included unless responsibility is legally binding.

Need help?

You can contact Compressed Air Alliance via:

- Phone
 - Australia: 1300 558 526
 - International: +61 494095632
- What'sApp: +61 494 095 632
- E-mail:
sales@compressedairalliance.com
- Website:
www.compressedairalliance.com



Compressed Air Alliance Pty Ltd

Address: 2/7 Narabang Way, Belrose NSW 2085, Australia

Phone / WhatsApp: +61 494095632

E-mail: sales@compressedairalliance.com

Website: www.compressedairalliance.com