



# User Manual

## Rogowski Coil with 4-20mA or Modbus Integrator

Model: ROG



# Table of Contents

Notices.....	3
Warnings.....	3
About Rogowski Coils .....	4
Specifications.....	6
Installation – Mechanical.....	9
Installation – Electrical .....	11
Warranty.....	13
Need help?.....	14
Appendix 1 – Modbus Communication Protocol.....	16
Appendix 2 – Configuring Modbus using Modbus Poll.....	30

# Notices

Please read this manual in full and carefully observe the notes and instructions before and during installation, operation and maintenance. The manufacturer cannot be held liable for any damage which occurs as a result of noncompliance with this manual.

**Do not tamper with device.** Should the device be tampered with in any manner other than a procedure which is described and specified in this manual, the warranty is cancelled and the manufacturer is exempt from liability.

**The product is designed exclusively for the described application.** Use of this product in conditions not specified in this manual or, contrary to the instructions provided by the manufacturer, is considered improper handling of the product and will void your warranty. The manufacturer will not be held liable for any damages resulting from improper use of the product.

This manual should be read carefully by relevant personnel and the end user. This manual should be kept with the product and be made available as needed. **Once you install or use the product, you accept that you have read, understood and complied with this manual.**

Compressed Air Alliance endeavours to make the content of this manual correct, but is not responsible for omissions or errors and the consequences caused. In case of any doubts or questions regarding this manual or the product, please contact Compressed Air Alliance.



## Warnings

**Ignoring the warnings can lead to serious injury and/or cause damage!**

When handling, operating or carrying out maintenance on this product, personnel must employ safe working practices and observe all local health & safety requirements and regulations.

Improper operation or maintenance of this product could be dangerous and result in an accident causing damage to machinery or injury or death.

The manufacturer cannot anticipate every possible circumstance which may represent a potential hazard. The warnings in this manual cover the most common potential hazards and are therefore not all-inclusive. If the user employs an operating procedure, an item of equipment or a method of working which is not specifically recommended by the manufacturer they must ensure that the product will not be damaged or made unsafe and that there is no risk to persons or property.

**NEVER CHANGE ORIGINAL COMPONENTS WITH ALTERNATIVES.**

# About Rogowski Coils

## What is a Rogowski coil?

Rogowski coils are a flexible current transducers that have been used for the detection and measurement of electric currents for decades. They are based on a simple principle: an “air-cored” coil is placed around the conductor in a toroidal fashion and the magnetic field produced by the current induces a voltage in the coil. The voltage output is proportional to the rate of change of current. This voltage is integrated, thus producing an output proportional to the current.

By using precision winding techniques, especially developed for the purpose, the coils are manufactured so that their output is not influenced by the position of the conductor within the toroid, and to reject interference from external magnetic fields caused, for example, from nearby conductors.

Basically, a Rogowski coil current measuring system consists of a combination of a coil and conditioning electronics. Rogowski coil current transducers are used for AC measurement.

The transducer does not measure direct currents but, unlike a current transformer, it can carry out accurate measurements of AC component even if there is a large superimposed

DC component, since there is no iron core causing saturation. This feature is particularly useful for measuring ripple currents for example in battery charging systems.

Rogowski coils can be used in similar circumstances to current transformers but for many applications they have considerable advantages:

- Wide dynamic range
- High linearity
- Very useful with large size or awkward shaped conductors or in places with limited access
- Unlike traditional current transducers, there is no danger from open-circuited secondaries
- They cannot be damaged by large overloads
- Measurement uniformity at any position of the conductor inside the coil
- They are non-intrusive
- They are light weighted and in some applications are light enough to be suspended on the conductor being measured
- Excellent degree of rejection to the external current conductor

## What does the Integrator do?

The integrator is a built-in analog integral circuit, which calculates true RMS and converts the coil's output into a 4-20mA or Modbus standard signal. The integrator is powered by 24VDC.

Rogowski coil output is a weak voltage (mV) signal. The integrator has ability to amplify and convert it to standard signal which can be read by power meters, your PLC or display.

Rogowski coil output is proportional to the frequency of the measured current. The signal equalization ensures a linear response on a wide frequency range. The integrator allows you to use coils on different electrical network frequencies, keeping the same output level over the frequencies.

An integrator is essential to equalize and shift the output signal from the Rogowski coils by 90°. It consists of an active electronic circuit with negligible offset and a good linearity.



Rogowski Coil



Integrator

# Specifications

## Rogowski Coil

	500 Amps	1,000 Amps	3,000 Amp
Rogowski Coil Size	500 Amps	1,000 Amps	3,000 Amp
Coil Length	200 mm or 7.87"	350 mm or 13.78"	510 mm or 20.08"
Window Size	50 mm or 1.97"	100 mm or 3.94"	150 mm or 5.91"
Ratio - Calibrated	85mV / kA@50Hz / 100mV / kA@50Hz		
Ratio - Uncalibrated	110mV / kA@50Hz		
Read Accuracy - Calibrated	<0.5% (central position, 25°C)		
Read Accuracy - Uncalibrated	< 5% tolerance (central position, 25°C)		
Maximum Current Measurable	100kA		
Coil Resistance	from 100 to 250 Ω		
Position Error	±1% maximum		
Phase error	≤0.5°		
Shielded	00% coil, 100% output cable		
Couplings	PA6 UL 94 V-0 rated		
Voltage Insulation	Coil: 3000V Signal cable: 1000V		
Compliance	LVD EN 61010-1:2010 EMC EN 61326-1:2013		
Safety	1000V CATIII ,600V CATIV		
Materials	Coil & cable: Thermoplastic rubber, flame retardant UL 94 V-0 rated		
Lead Length	5 meters		

Operation Temperature	-20°C to +70°C	-4°F to 158°F
Storage Temperature	-30°C to +90°C	-22°F to 194°F
Installation Type	Temporary or permanent installation	
Warranty	12 months	

## Integrator

	Modbus (RS485) Integrator	Analogue (4-20mA) Integrator
Output Signal	RS485	4-20mA
Amplitude Accuracy	25mA DC	
Linearity	±0.2% (10% to 100% F.S.)	±0.2% (1% to 200% of range)
Bandwidth	30Hz to 5kHz	30Hz to 1kHz
Temperature Drift	50ppm/°C	200ppm/°C
Phase Error	≤0.5°	
Power Supply	24V (0.5W or above)	24V (0.5W or above)
Size	114mm x 42mm x 29mm 4.5" x 1.7" x 1.1"	53mm x 38mm x 25mm 2.1" x 1.5" x 1.0"
Weight	20 grams	
Materials	PC	
Operation Temperature	-20°C to +70°C	-4°F to 158°F
Storage Temperature	-30°C to +90°C	-22°F to 194°F

## Position Sensitivity



Conductor Position		Typical Error (%)
●	Adjacent to the center of coil	0.2%
●	Adjacent to the inside coil	<1%

## Dimensions

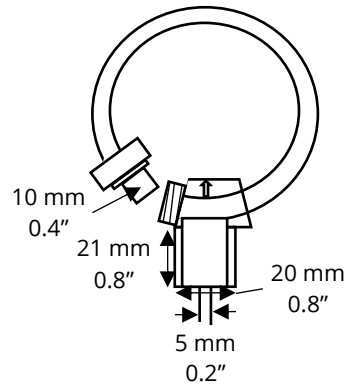
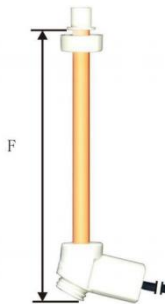
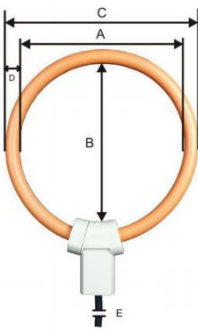

	500 Amps	1,000 Amps	3,000 Amp
A Windows size A	50 mm	105 mm	155 mm
B Windows size B	60 mm	100 mm	150 mm
C Coil Outer Diameter	66 mm	121 mm	171 mm
D Coil section	8 mm		
E Lead Cable Total Length	5 meters		
F Coil length	200 mm	350 mm	510 mm



# Installation – Mechanical



**WARNING!** Risk of electrical shock.

Any contact with energised parts of the product, may lead to an electrical shock which can lead to serious injuries or even death. The user shall take all measures necessary to protect against electrical shock.



## Notes

- Users should be suitably qualified, licensed and experienced to install, operate, maintain and remove this product
- **Before installing the product, make sure it is rated for your system** (refer to the “Specifications” section).
  - Use of the product outside specified ranges or operating parameters can lead to malfunctions and may damage the product or system.
- The system must be disconnected from any power supply during maintenance work.
- When operating the Rogowski Coil, certain parts of the module may carry hazardous live voltage (e.g. primary conductor). The user shall take all measures necessary to protect against electrical shock. The Coil’s transducer is a built-in device containing conducting parts that shall not be accessible after installation. A protective enclosure or additional insulation barrier may be necessary.
- Do not use this product in explosive areas.
- Do not stress the coil by applying any kind of mechanical force (i.e. twisting, puncturing, excessive pressure, tight bending, etc.) as this will dramatically degrade the device’s accuracy.
- Do not disassemble the product.
- Please observe local and national regulations before/during installation and operation.
- The product must be installed properly, otherwise it may lead to inaccurate measurement values.
- Incorrect installation can damage the product, cause it to work incorrectly or result in injury or death.

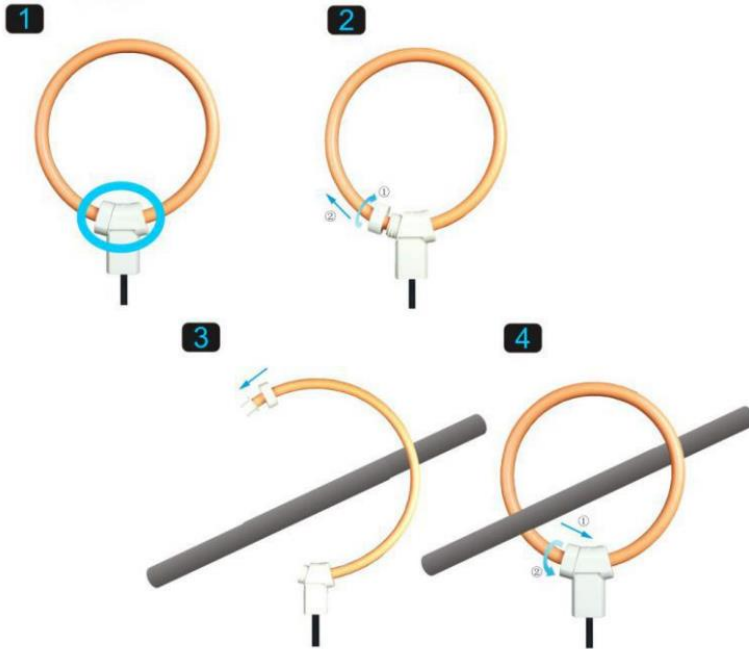

Installation and maintenance shall be done with the main power supply disconnected except if there are no hazardous live parts in or in close proximity to the system. Local and national regulations must be fully observed.

**Step 1** – Locate clip on the base unit

**Step 2** – Unscrew clip and pull out coil from base unit

**Step 3** – Place coil over conductor, ensuring arrow faces toward the load

**Step 4** – Insert coil back into base unit and screw clip to secure the coil

# Installation – Electrical



## **WARNING! Risk of electrical shock**

Incorrect wiring or contact with energised parts of the product, may lead to an electrical shock which can lead to serious injuries or even death. The user shall take all measures necessary to protect against electrical shock.



## Notes:

- Always check the coloured wires to make sure they are wired correctly.
- Consider all local and national safety requirements and regulations for electrical installations.
- **The system must be disconnected from any power supply during installation and maintenance work.**
- Any electrical work on the system is only allowed by authorised and qualified personal.

	Rogowski Coil with <b>Modbus (RS485) Integrator</b>	Rogowski Coil with <b>Analogue (4-20mA) Integrator</b>
<b>Red Wire</b>	Power supply +24V DC	Power supply +24V DC
<b>Blue Wire</b>	Ground	Ground
<b>Green Wire</b>	A port of RS485 (Data +)	Signal ground
<b>Yellow Wire</b>	B port of RS485 (Data -)	4 to 20 mA signal

## Wiring - Modbus (RS485)

Rogowski Coil with Modbus (RS485) Integrator	
Red Wire	Power supply +24V DC
Blue Wire	Ground
Green Wire	A port of RS485 (Data +)
Yellow Wire	B port of RS485 (Data -)

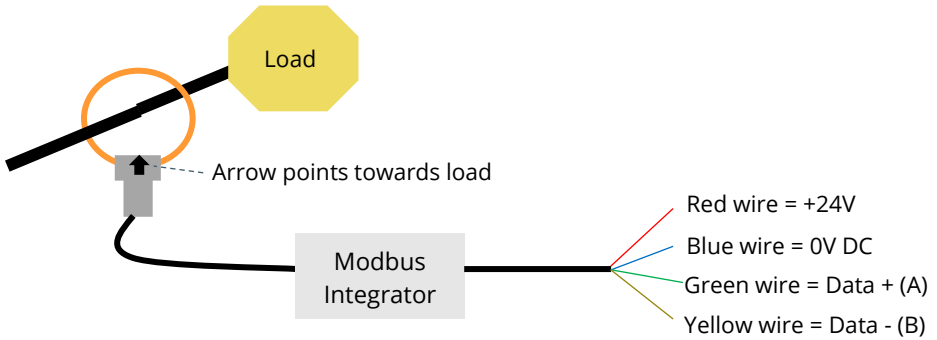

## Wiring - Analogue (4-20mA)

Rogowski Coil with Analogue (4-20mA) Integrator	
Red Wire	Power supply +24V DC
Blue Wire	Ground
Green Wire	Signal ground
Yellow Wire	4 to 20 mA signal

### Scaling

- 4 mA = 0
- 20 mA = 500, 1000 or 3000 depending on coil selection

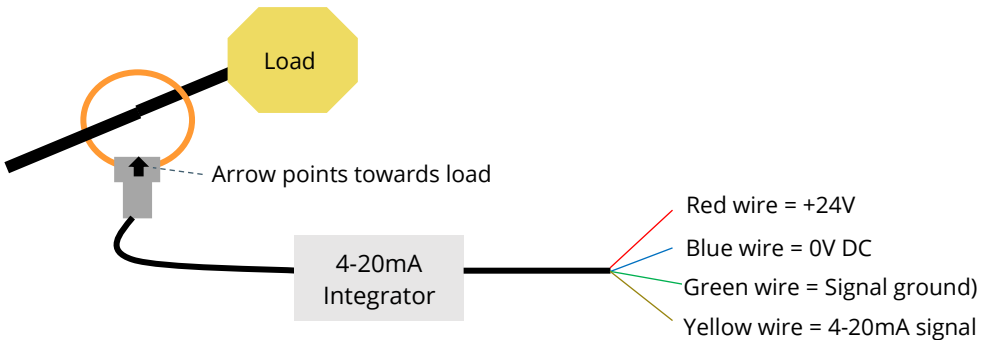

# Warranty

Compressed Air Alliance provides a 12-month warranty for all Rogowski Coils. The warranty covers materials and workmanship under the stated operating conditions from the date of delivery. Please report any findings immediately and within the warranty time.

If faults occur during the warranty period Compressed Air Alliance will repair or replace the defective unit, without charge for repair labour and material costs but there is a charge for other services such as labour to remove or reinstall the instrument, transport and packing. Warranty repairs do not extend the period of warranty.

The following damage is excluded from this warranty:

- Improper use and non-adherence to the user manual.
- Use of unsuitable accessories.
- External influences (e.g. damage caused by vibration, damage during transportation, excess heat or moisture).

The warranty is cancelled when one of the following situations occurs:

- The user opens the measurement instrument

without a direct request written in this manual.

- Repairs or modifications are undertaken by third parties or unauthorised persons.
- The serial number has been changed, damaged or removed.

Other claims, especially damage occurring on the outside of the instrument (eg dents, marks), are not included unless responsibility is legally binding.

## Need help?

You can contact Compressed Air Alliance via:

- Phone (Australia): 1300 558 526
- E-mail: [sales@compressedairalliance.com](mailto:sales@compressedairalliance.com)
- Website: [www.compressedairalliance.com](http://www.compressedairalliance.com)

# Appendices

## For Modbus Integrator

Appendix 1 – Modbus Communication Protocol

Appendix 2 - Configuring Modbus using Modbus Poll

# Appendix 1 – Modbus Communication Protocol

The Modbus (RS485) integrator adopts the standard protocol - Modbus-RTU. Baud rate of communication can change to 1200, 2400, 4800, 9600, etc. through programming. Error detection: CRC16 (cyclic redundancy check).

## Modbus RS485 Communication Settings

Parameters	Available Valves	Default Valves
Baud rate	1200 2400 4800 9600 19200	9600
Parity	Odd Even None	None
Data Bits	8	8
Stop Bits	1	1
Address	1 to 247	1

## Request Instruction Format

Slave Address	Function Code	Command Block	CRC
8-Bits	8-Bits	N×8-Bits	16-Bits



## Functional Code

Functional code tells what function addressed terminal equipment can execute. The following table lists the functional code that used by this instrument, as well as their significance and function.

Function Code		Function Name	Behaviour
Decimal	Hexadecimal		
3	03H	Read Holding Registers	Read present HEX from one or more registers
16	10H	Write Multiple Registers	Write present HEX on multiple registers

## Register Table

Register tables have the following columns:

Register Alias	Register Address	Action R/WC	Size	Type	Units	Description
----------------	------------------	-------------	------	------	-------	-------------

**Register Alias:** The meaning of the register

**Register Address:** Modbus address of register encoded in the Modbus frame, in decimal (dec)

**Action:** The read/write by command register

**Size:** The data size in Int16

**Type:** The encoding data type

**Units:** The unit of the register value

**Range:** The permitted values for this variable, usually a subset of what the format allows

## CRC check method

Redundant Cyclic Code (CRC) contains 2 bytes, i.e 16-bit binary. CRC code is calculated by the sending device and placed at the end of the sending message. The receiving device recalculates the received CRC code, compares whether the calculated CRC code is consistent with the received one, and if the two do not match, it indicates an error.

CRC code calculation method is first preset, 16-bit registers are all 1. Then step by step every 8 bits of data information processing. Only 8 bit data, start bit and stop bit are used in CRC code calculation, and if there is parity bit, parity bit is also included but it does not participate in CRC code calculation.

At the time of calculating the CRC code, the 8-bit data is different from the register data, and the result is one byte to the low position and fills the highest bit with 0. Check the lowest bit again, if the lowest bit is 1, the contents of the register are different from the preset number or, if the lowest bit is 0, no XOR operation is carried out. This process has been repeated 8 times. After the eighth shift, the next 8 bits are different from the contents of the current register, and this process is repeated 8 times as above. After all the data information is processed, the final register is CRC code value. CRC data in the code send, receive when the low byte before.

Compute the CRC code by:

1. Preset 16-bit register is hexadecimal FFFF (that is, all 1), which is called CRC register.
2. The first 8-bit data is different from the low position of the 16-bit CRC register and the result is placed in the CRC register.
3. Move the contents of the register to the right (low), fill the highest bit with 0, check the lowest bit.
4. If the lowest position is 0: repeat step 3 (shift again).
  - When the lowest bit is 1: CRC register is A001(10100000 with polynomial 0000 0001.
5. Repeat steps 3 and 4, eight times to the right. In this way, the entire 8-bit data is processed.
6. Repeat steps 2 through 5 to process the next 8-bit data.
7. Final CRC register is the CRC code.

## List of data types

The following table lists the data types that this document may use:

Type	Description	Range
UInt8	8-bit unsigned integer	0 - 255
UInt16	16-bit unsigned integer	0 - 65535
Int16	16-bit signed integer	-32768 - +32767
UInt32	32-bit unsigned integer	0 - 4 294 967 295
UInt64	64-bit unsigned integer	0 - 18 446 744 073 709 551 615
UTF8	8-bit field	Multibyte character encoding for Unicode
Float32	32-bit value	Standard representation IEEE for floating number (with single precision)
Bitmap	-	-
Date Time	-	-

**Definition description of data byte direction:** Except for the CRC-16 check code at the end of the instruction, the order of receiving and sending bytes is low bytes before, and the order of receiving and sending bytes of all other data is high bytes before.

## Function Code (3) Operating Instructions

Read device parameter instruction format:

No.	Alias	Type	Range	Description
1	Slave ID	UInt8	0 – 127	Address 0 for point-to-point communication only
2	Function Code	UInt8	3	
3	Register Start Address	UInt16	-	High byte before
4	Number of Read Registers	UInt16	1 – 127	High byte before
5	CRC-16 Verification Code	UInt16	-	Low byte before

Return device parameter instruction format:

No.	Alias	Type	Range	Description
1	Slave ID	UInt8	0 – 127	Address 0 for point-to-point communication only
2	Function Code	UInt8	3	
3	Data byte length	UInt8	-	Number of registers*2
4	Register 1 data	UInt16	-	High byte before
5	....	UInt16	-	High byte before
6	Register 1 data	UInt16	-	High byte before
7	CRC-16 Verification Code	UInt16	-	Low byte before

Description of use of device address 0 for function code 3:

Device address 0, can only be used for point-to-point communication, that is, one host and one slave, can not be used for multiple slave communication

When the device address is 0, the host does not need to know the slave address to read the data from the slave

When you forget the slave address, you can use the 0 device address to read the slave's real address by the specified address

### Read device parameters for example:

Read current value (address 100 starts):

No.	Alias	Type	Value (decimal)	Value (hexadecimal)	Description
1	Slave ID	UInt8	1	01	
2	Function Code	UInt8	3	03	
3	Register Start Address	UInt16	100	0064	Current starting address
4	Number of Read Registers	UInt16	2	0002	2 registers
5	CRC-16 Verification Code	UInt16	54405	D485	

Send hexadecimal bytes in the following order: **01 03 00 64 00 02 85 D4**

The packets received are as follows: **01 03 04 43 FA 00 00 CF 86**

### Analysis:

No.	Alias	Type	Value (decimal)	Value (hexadecimal)
1	Slave ID	UInt8	01	1
2	Function Code	UInt8	03	3
3	Data byte length	UInt8	04	4

No.	Alias	Type	Value (decimal)	Value (hexadecimal)
4	Address 10 data (current)	Float32	43FA0000	500
7	CRC-16 Verification Code	UInt16	CF86	

## Function Code (16) Operating Instructions

Function code16 is used to configure device parameters. The request and return instructions are defined as follows.

Configuration Device Parameter Instruction Format:

No.	Alias	Type	Range	Description
1	Slave ID	UInt8	0 – 127	
2	Function Code	UInt8	16	
3	Register Start Address	UInt16	-	High byte before
4	Number of Configuration Registers	UInt16	1 – 127	High byte before
5	Data Byte Length	UInt8	-	Number of configuration registers*2
6	Register 1 data	UInt16	-	High byte before
7	....	UInt16	-	High byte before
8	N register configuration data	UInt16	-	High byte before
9	CRC-16 Verification Code	UInt16	-	Low byte before

Return device parameter instruction format:

No.	Alias	Type	Range	Description
1	Slave ID	UInt8	0 – 127	
2	Function Code	UInt8	16	
3	Register Start Address	UInt8	-	High byte before
4	Number of Configuration Registers	UInt16	0 – 127	High byte before
5	CRC-16 Verification Code	UInt16	-	Low byte before

The device parameter configuration can only be configured by writing the corresponding data to the device parameter configuration register, that is, to write the corresponding data to the address starting from 300, which is used to configure the corresponding parameters.

## Configure Equipment

You can configure the device by RS485/Modbus, writing the corresponding instruction code and parameters to the instruction register (starting from address 300) with Function code 16.

## Configuration Request

The following table lists the configured generic packet formats:

Address	Function Code	Instruction Register	Number of instruction registers	Data Length	Write Instruction Register Value	CRC-16 Verification
1 – 247	16	300	N	Nx2		

## Examples of Configuration Requestions

The following table lists the configuration equipment communication parameters. The device communication parameters are configured as: address=2, baud rate=9600, check=no check

No.	Alias	Type	Value (decimal)	Value (hexadecimal)	Description
1	Slave ID	UInt8	1	01	
2	Function Code	UInt8	16	10	
3	Register Start Address	UInt16	300	012C	Register start address
4	Number of Configuration Registers	UInt16	4	0004	Instruction parameters occupy 4 registers
5	Data Byte Length	UInt8	8	08	Number of configuration registers*2
6	Register 300 Write Value	UInt16	1002	03EA	Configuring Communication Instruction Code =1002
7	Register 301 Write Value	UInt16	2	0002	Config address = 2
8	Register 302 Write Value	UInt16	3	0003	Configuration of communication baud rate = 9600
9	Register 303 Write Value	UInt16	2	0002	Configuration communication checks = no checks
10	CRC-16 Verification Code	UInt16	36390	8E26	

The order of sending bytes is as follows: **01 10 01 2C 00 04 08 03 EA 00 02 00 03 00 02 26 8E**

Configuration successfully returns data: **01 10 01 2C 00 04 01 FF**



**Analysis:**

No.	Alias	Type	Value (decimal)	Value (hexadecimal)
1	Slave ID	UInt8	01	1
2	Function Code	UInt8	10	16
3	Register Start Address	UInt16	012C	300
4	Number of Configuration Registers	UInt16	0004	4
7	CRC-16 Verification Code	UInt16	01FF	

**Note:** All reserved parameter values should be set to 0.

**Error return instruction description**

When the above instruction or instruction parameter error, the device will return a piece of data to explain the cause of the error, the data format is as follows:

Slave ID (UInt8)	Function Code (UInt8)	Error Code (UInt8)		CRC-16 (UInt16)
1	Function code 0x80 request	Error Code	Alias	
		1	Function code not supported	
		2	Invalid data address	
		3	Data values do not meet requirements	
		4	Data Read and Write Error	

## Configuration Instruction Register List

No.	Alias	Operation	Size	Type	Unit	Description
Instruction code	300	R/W	1	UInt16	-	
Instruction parameters 001	301	R/W	1	UInt16	-	
Instruction parameters 002	302	R/W	1	UInt16	-	
....	...	R/W	1	UInt16	-	
Instruction parameters 123	423	R/W	1	UInt16	-	

## Setting the Communication Parameters

Instruction Code	Operation	Size	Types	Unit	Range	Description
1002	W	1	UInt16	-	1 - 247	Address
	W	1	UInt16	-	0, 1, 2, 3, 4	Baud Rate 0=1200 1=2400 2=4800 3=9600 4=19200
	W	R/W C	UInt16	-	0, 1, 2	Even-Odd Check 0=Odd 1=Even 2=None

## Modbus Register List

Register Name	Register Address	Operation	Size	Type	Unit	Description
Unit Type	50	R	10	UTF8	-	
Serial Number	70	R	2	UInt32	-	
Firmware Version number	72	R	1	UInt16	-	Data format: X.Y.ZTT
Calibration Data & Time	73	R/WC	4	Date/Time	-	Register 73: <b>year</b> 00-99 (from 2000 to 2099)  Register 74: <b>month</b> (b15 : b8), <b>day</b> (b7 : b0)  Register 75: <b>hour</b> (b15 : b8), <b>minutes</b> (b7 : b0)  Register 76: <b>milliseconds</b>

## Communicational Parameter

Register Name	Register Address	Operation	Size	Type	Unit	Description
Address	80	R/WC	1	UInt16	-	1 - 247
Baud Rate	81	R/WC	1	UInt16	-	0=1200 1=2400 2=4800 3=9600 4=19200
Verification method	82	R/WC	1	UInt16	-	0=odd 1=even 2=none

## Current Value

Register Name	Register Address	Operation	Size	Type	Unit	Description
Current	100	R	2	Float32	A	Current Value

## Factory Settings

Below are the factory settings for use when calibrating the Modbus Integrator. Unauthorized operation may lead to serious problems! Please consult us before using.

### Setting Sensor Ratio

Configuration Instructions	Read/Write	Size	Type	Unit	Value Range	Description
10	W	1	UInt16	A	>0	Primary end of sensor, nominal current value

Configuration Instructions	Read/Write	Size	Type	Unit	Value Range	Description
	W	1	UInt16	mV	>0	Sensor secondary, output voltage *100

### Set the serial number of the device

Configuration Instructions	Read/Write	Size	Type	Unit	Value Range	Description
3	W	1	UInt32		>0	Equipment Series

### Calibration of current values

Configuration Instructions	Read/Write	Size	Type	Unit	Value Range	Description
11	W	1	UInt16		>19 <30	Year
	W	1	UInt16		>0 <13	Month
	W	1	UInt16		>0 <32	Day
	W	1	UInt16		>0 <24	Hour
	W	1	UInt16		>0 <60	Minute
	W	1	UInt16		>0	Second
	W	1	UInt16	A	>0	Calibration current* 10

### Sensor Ratio

Register Name	Register Address	Operation	Size	Type	Unit	Description
Pri	1000	R	2	UInt16	A	Primary end of sensor, nominal current value
Sec	1001	R	2	UInt16	mV	Actual value = read value /100

# Appendix 2 – Configuring Modbus using Modbus Poll



This appendix describes how to use **Modbus Poll** to update Modbus settings. If you use another Modbus program, please ignore this appendix. Appendix 1 has the Modbus communication protocol.

## Tools and Equipment needed

(not supplied with Rogowski Coil)

- 24vDC Power Supply
- USB/RS485 Converter
- Modbus Poll software

Modbus Poll is a Modbus master simulator that allows you to update Modbus settings of your product. You can download Modbus Poll software from <https://www.modbustools.com/download.html>. The free version of Modbus Poll only allows you to connect to a sensor for limited periods, however this is generally enough time to program the Modbus integrator. If you intend to use Modbus Poll for more than 30 days, you will need to buy a license. Refer to the Modbus Poll website for more information.

## Basic Steps for configuring Modbus using Modbus Poll

- **Step 1** – Connect Rogowski Coil to **24vDC** power supply
- **Step 2** – Connect Rogowski Coil to USB/RS485 converter
- **Step 3** – Connect USB/RS485 convertor to computer
- **Step 4** – Open Modbus Poll and connect to Rogowski Coil
- **Step 5** – Configure Modbus settings
- **Optional Step** – Change Modbus settings
- **Optional Step** – Check Rogowski Coil configuration

## Step 1 - Connect Rogowski Coil to 24vDC Power Supply



**WARNING.** Make sure you connect the Rogowski Coil to **24vDC** otherwise permanent damage can be done to the Modbus Integrator.

- Connect the red and blue wires to the 24vDC power supply – see picture below.
  - Red wire: +24vDC
  - Blue wire: 0vDC
- Always check the coloured wires to make sure they are wired correctly.

## Step 2 - Connect Rogowski Coil to USB/RS485 Converter

- Connect the Green and Yellow wires to the USB/RS485 converter – see picture below.
  - Green wire: RS485 Data + (A)
  - Yellow wire: RS485 Data - (B)
- Always check the coloured wires to make sure they are wired correctly.

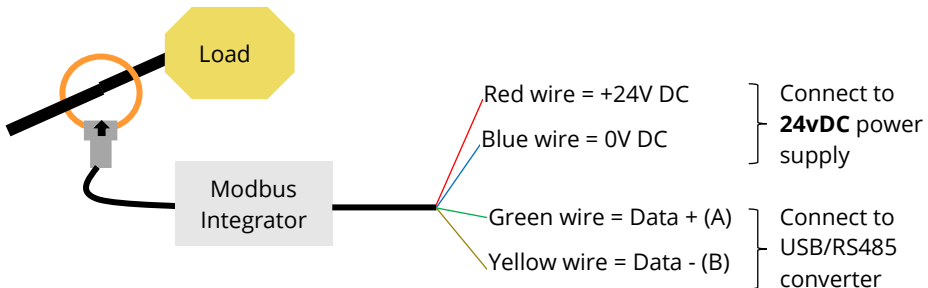

Rogowski Coil with Modbus (RS485) Integrator	
Red Wire	Power supply +24V DC
Blue Wire	Ground
Green Wire	A port of RS485 (Data +)
Yellow Wire	B port of RS485 (Data -)

## Step 3 - Connect USB/RS485 converter to computer

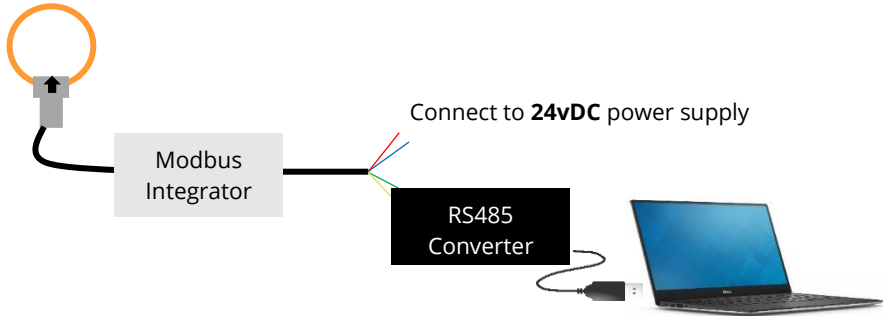

- Plug the USB/RS485 converter into one of your computer's USB ports.
  - The preference is to connect the converter to the COM1, COM2 or COM3 port.
- On your computer, go to **"Device Manager" > "Ports (COM & LPT)"** and check which port the RS485 converter is assigned to.
  - The RS485 converter should be assigned to "USB Serial Port (COM1)", OR "USB Serial Port (COM2)" OR "USB Serial Port (COM3)". In the diagram below, the RS485 converter is assigned to "USB Serial Port (COM1)".

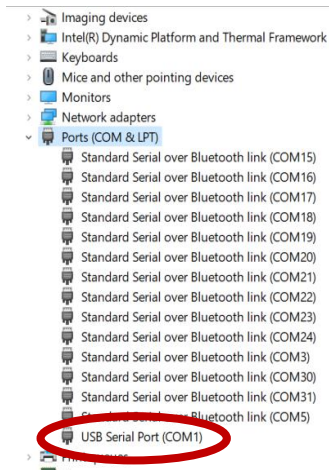



- If the RS485 converter is assigned to another COM Port (eg COM4, COM5, etc), you will need to reassign the converter to COM1, COM2 or COM3.
  - To do this: right click on device, select "Properties", select "Port Settings" tab > "Advanced" settings and change the COM port accordingly. **DO NOT CHANGE ANY OTHER SETTINGS IN THESE TABS.**

## Step 4 - Open Modbus Poll and connect to Rogowski Coil

- On your computer, open "Modbus Poll" software

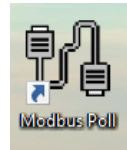

- In Modbus Poll, select the "Connection" Tab > "Connect"

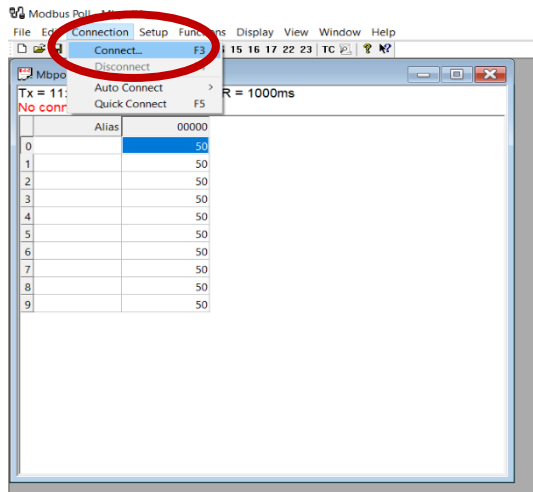

## Step 5 - Configure Modbus settings

- Select correct settings:
  - Ensure **'Serial Settings'** is set to the correct COM port for your device. Eg, if you connected the RS485 converter to COM2, then select 'USB Serial Port (COM2)' from the drop down list
- Enter the **default Modbus settings**: 9600 Baud, 8 Data Bits, None Parity, 1 Stop Bit
- Click 'OK'.

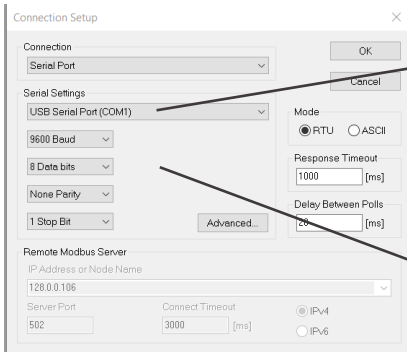

Ensure 'Serial Settings' is set to the correct COM port for your

Default settings are:  
 9600 Baud  
 8 Data Bits  
 None Parity  
 1 Stop Bit

- Go to the **"Setup"** Tab > **"Read/Write Definition"**

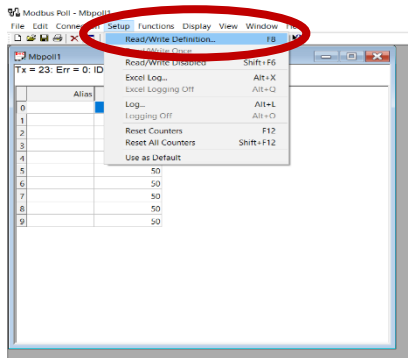

- Match Slave address to the power meter.
  - The default setting is 1. However, you may need to try several different numbers to find the right one.
- Click 'OK'.

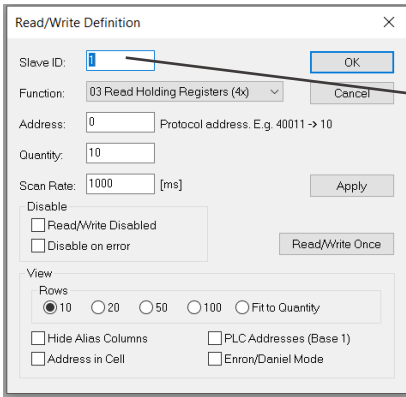

Default slave ID is 1

If setup is correct, Modbus Poll should display the following information in the open window. **Note:** "Tx" will continue to count upwards.

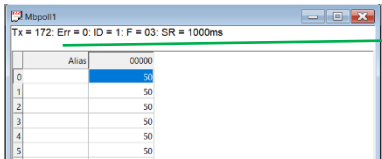

Slave Address is correct  
No error message

If you get a **"Timeout Error"** message, the Rogowski Coil's Modbus Integrator is not set up correctly. Check your Modbus settings (Slave Address, Comm Port, Baud Rate, etc), then go back to the start of Step 5 and enter the correct information.

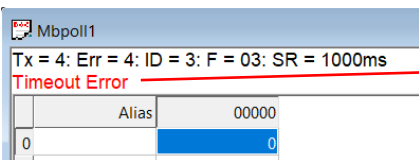

Slave address is wrong  
Timeout error message

## Optional - Change Modbus settings



**Note:** This section only applies if you need to change the Modbus settings.

- Select **“Functions”** Tab > **“16. Write Registers”**

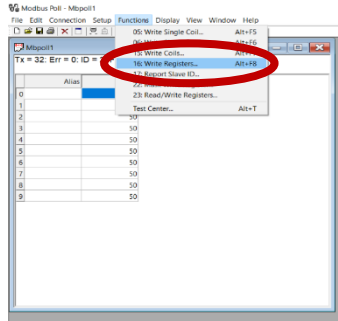

- Make sure the Slave ID matches the power meter.
- Change Address to **300**
- Change Quantity to **4**
- Change Type to **Hex**
- Double click on each register (300, 301, 302, 303) to edit their settings (see next page for settings).

Slave ID = 1  
(or the current Modbus Address if previously changed)

**16: Write Multiple Registers**

Slave ID:

Address:

Quantity:

Type:

300 = 0x0000

301 = 0x0000

302 = 0x0000

303 = 0x0000

Send  
Cancel  
Edit

Update registers 300, 301, 302, 303

Address = 300  
Quantity = 4  
Type = HEX



**WARNING:** All 4 registers (300, 301, 302, 303) must be filled in prior to selecting “Send”. Failure to do so will result in a permanent setting error of the sensor that cannot be recovered.



**WARNING:** Data for Registers 300, 301, 302, 303 are entered in HEX format, **not** binary/decimal. Use your computer calculator to convert decimal to hex by changing the calculator type to “Programmer”.

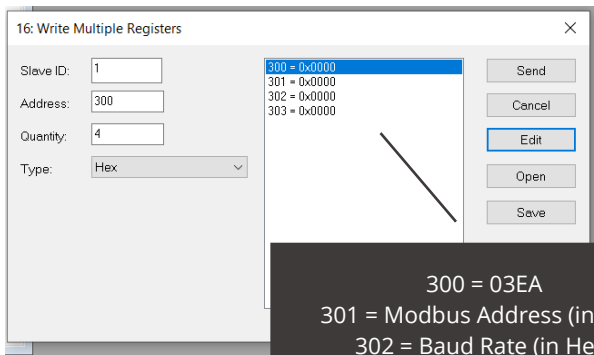

300 = 03EA  
 301 = Modbus Address (in Hex)  
 302 = Baud Rate (in Hex)  
 303 = Parity (in Hex)

Edit the 300, 301, 302 and 303 registers as follows:

- Double click on register “**300**” and enter **03EA**. Then click “OK”
- Double click on register “**301**” and enter the desired **Modbus address** for the unit in HEX FORMAT, then click “OK”.
  - To get the Modbus Address in HEX, enter the Modbus Address into your calculator to get the HEX code. Enter the **HEX** code into 301
  - Example: If the Modbus Address = 2 (in DEC), the HEX code = 0002. Enter 0002 into Register 301.

- Example: If the Modbus Address = 40 (in DEC), the HEX code = 0028. Enter 0028 into Register 301.
- Example: if the Modbus Address = 123 (in DEC), the HEX code = 007B. Enter 007B into Register 301.
  
- Double click on register “302” and enter the desired **Baud Rate** for the unit, then click “OK”:
  - For a Baud Rate of 1200, enter 0000
  - For a Baud Rate of 2400, enter 0001
  - For a Baud Rate of 4800, enter 0002
  - For a Baud Rate of 9600, enter 0003 (Default)
  - For a Baud Rate of 19200, enter 0004
  
- Double click on register “303” and enter the desired **Parity** for the unit, then click “OK”
  - 0000 = ODD
  - 0001 = EVEN
  - 0002 = NONE (Default)



**WARNING:** All 4 registers (300, 301, 302, 303) must be filled in prior to selecting “Send”. Make sure all 4 registers have the correct information. Failure to do so will result in a permanent setting error of the sensor that cannot be recovered.

- Once you are sure the Modbus settings are correct, click “Send”
  - **Tip:** Write the Modbus settings on the back of the Modbus Integrator so you don’t forget them



**Note:** When you hit Send, you will get an error message. **This is normal.** The error message appears because the Modbus settings have changed and the Rogowski Coil can’t communicate with Modbus Poll.

- Close the error message and close the setting box.
- Disconnect then reconnect the Rogowski Coil using the new Modbus settings (see next page).

**Example:**

This device is set to:

- Modbus Address: 2 (301 Hex code: 0002)
- Baud Rate: 9600 (302 Hex code: 0003)
- Parity: NONE (303 Hex code: 0002)

```
300 = 0x03EA
301 = 0x0002
302 = 0x0003
303 = 0x0002
```

To disconnect, then reconnect the Rogowski Coil to Modbus Poll, go to:

- Connection > Disconnect
- Connection > Connect
- Follow Step 5 (above) to enter the correct Modbus settings (Baud Rate, Parity & Slave ID)
- Go to **Setup > Read/Write Definition** and change the Slave ID to the new address.

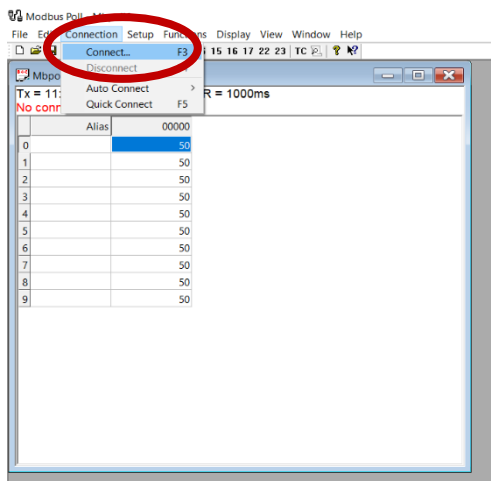

## Optional Step - Check Rogowski Coil Settings

- Go to **“Setup” > “23.Read/Write Definition”**
- Make sure the Slave Address is correct.
- Change ‘Address’ to the first register you want to read (see following pages for the Addresses).
  - Example: if you want to check the Rogowski Coil Current rating, change the Address to ‘100’
  - Example: if you want to check the Modbus Address and Baud Rate, change the Address to ‘80’
- Change ‘Quantity’ to 3. This will show you 3 registers. If you want to see 10 registers, change ‘Quantity’ to 10
  - Example: If the Address = 100 and the Quantity = 3, only 3 Registers will be shown, ie Registers 100, 101 and 102 will be displayed.

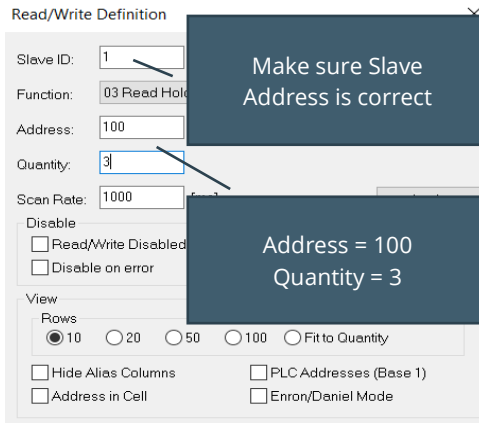

- The Modbus reading will be shown in the second (2<sup>nd</sup>) column. Check the results against the tables on the following pages.

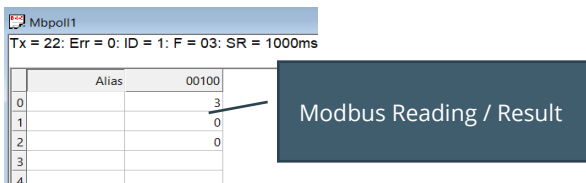



### To check the Rogowski Coil Rated Current

	Register	Modbus Reading	Description
Rogowski Coil Rated Current	100	1	100A
		2	600A
		3	1000A
		4	3000A
		5	6000A
Voltage Connection	104	0	Direct Connect
		1	3PH4W (3 VTs)
Current Connection	105	0	Rogowski coil
		1	CT

- Go to **“Setup” > “23.Read/Write Definition”**
- Make sure the Slave Address is correct.
- Change:
  - Address to 100
  - Quantity to 3
- The Reading on Row 0 (Register 100) = Rogowski Coil Rated Current.
  - Example: If row 0 (Register 100) = 2, the Rogowski Coil is rated for 600A
- The reading on Row 1 (Register 104) = Voltage Connection. This should = 0 for Direct Current
- The reading on Row 2 (Register 105) = Current Connection. This should = 0 for Rogowski coil

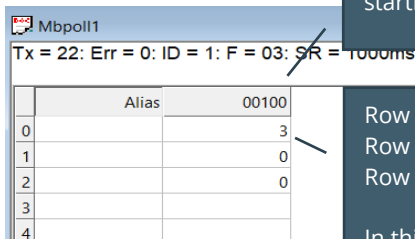

Reading 3 Registers (rows 0, 1, 2) starting at Register 100

Row 0 = Register 100 = Coil Rating  
 Row 1 = Register 104 = Voltage Connection  
 Row 2 = Register 105 = Current Connection

In this example, Row 0 = Register 100 = 3 = 1000A

## To check the Modbus Communication Settings

	Register	Modbus Reading	Description
Address	80	1 to 247	Slave address
Baud Rate	81	0	1200
		1	2400
		2	4800
		3	9600
		4	19200
		5	38400
Parity	82	0	Odd
		1	Even
		2	None
Data Bit	-	8	8
Stop Bit	-	1	1

- Go to **“Setup” > “23.Read/Write Definition”**
- Make sure the Slave Address is correct.
- Change:
  - Address to 80
  - Quantity to 3
- The Reading on Row 0 (Register 80) = Slave Address. (Default Slave Address = 1).
- The reading on Row 1 (Register 81) = Baud Rate
  - Example: If Row 2 (Register 81) = 5, the Baud rate is set to 38400
- The reading on Row 3 (Register 82) = Parity

This page is left blank intentionally



Compressed Air Alliance Pty Ltd

Address: 1 Arthur St, Dee Why NSW 2099, Australia

E-mail: [sales@compressedairalliance.com](mailto:sales@compressedairalliance.com)

Website: [www.compressedairalliance.com](http://www.compressedairalliance.com)